

# ADDISON™

## AIDF-SERIES INDIRECT-FIRED HEATING, COOLING and PRESSURIZATION SYSTEMS



### DIMENSION AND SELECTION GUIDE

[www.addison-hvac.com](http://www.addison-hvac.com)  
Telephone: +1.407.292.4400



# AIDF-SERIES UPRIGHT MODEL DIMENSIONS (35 - 125)

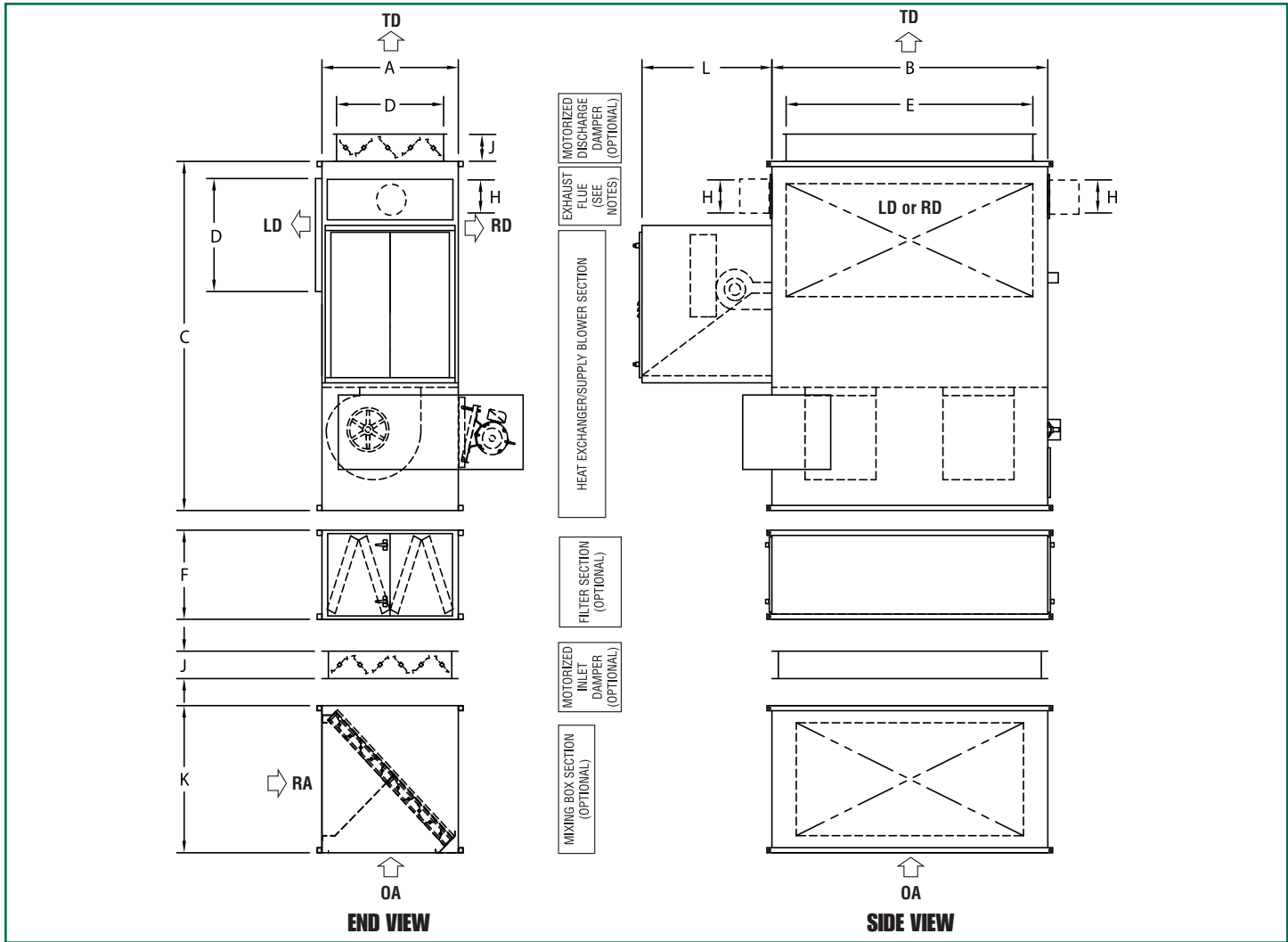

LEGEND	
<b>TD</b> = Top Discharge	<b>BD</b> = Bottom Discharge
<b>RA</b> = Return Air	<b>OA</b> = Outside Air
<b>RD</b> = Right Discharge	<b>LD</b> = Left Discharge
	<b>ED</b> = End Discharge

## IMPORTANT NOTES:

- Dimensions in black are in inches. Dimensions in green are in centimeters.
- Weights in black are in pounds. Weights in green are in kilograms.
- Shipping weights apply to both horizontal and upright models.
- All dimensions and weights are subject to change without notice.
- Some components may ship separately due to shipping constraints.
- Exhaust flue on AIDF-35 through AIDF-100 on opposite side as burner enclosure.
- Exhaust flue on AIDF-125 on same side as burner enclosure (Dimension H).
- Dimensions for filter sections only apply to those sections using permanent, polyester or pleated filters.
- Contact Addison for dimensions of filter sections using bag or cartridge filters.

MODEL	CABINET DIMENSIONS											FILTER SECTION FILTERS	
	A	B	C	D	E	F	G	H	J	K	L	QTY	SIZE
<b>AIDF-35/45</b>	30 (76.2)	60 (152.4)	90 (228.6)	21.5 (54.6)	50 (127.0)	28 (71.1)	38 (96.5)	6 (15.2)	8 (20.3)	43 (109.2)	40 (101.6)	6	20 x 20 x 2 (50.8 x 50.8 x 5.1)
<b>AIDF-50/65/75</b>	28 (71.1)	72 (182.9)	80 (203.2)	21.5 (54.6)	58 (147.3)	28 (71.1)	38 (96.5)	6 (15.2)	8 (20.3)	43 (109.2)	40 (101.6)	4	20 x 25 x 2 (50.8 x 63.5 x 5.1) 16 x 25 x 2 (40.6 x 63.5 x 5.1)
<b>AIDF-85/100</b>	36 (91.4)	72 (182.9)	90 (228.6)	26 (66.0)	58 (147.3)	24 (61.0)	48 (121.9)	8 (20.3)	8 (20.3)	43 (109.2)	40 (101.6)	8	20 x 20 x 2 (50.8 x 50.8 x 5.1) 16 x 20 x 2 (40.6 x 50.8 x 5.1)
<b>AIDF-125</b>	42 (106.7)	85 (215.9)	102 (259.1)	33 (83.8)	76 (193.0)	26 (66.0)	48 (121.9)	10 (25.4)	8 (20.3)	43 (109.2)	40 (101.6)	16	20 x 16 x 2 (50.8 x 40.6 x 5.1)
												4	20 x 20 x 2 (50.8 x 50.8 x 5.1)

# AIDF-SERIES HORIZONTAL MODEL DIMENSIONS (35 - 125)

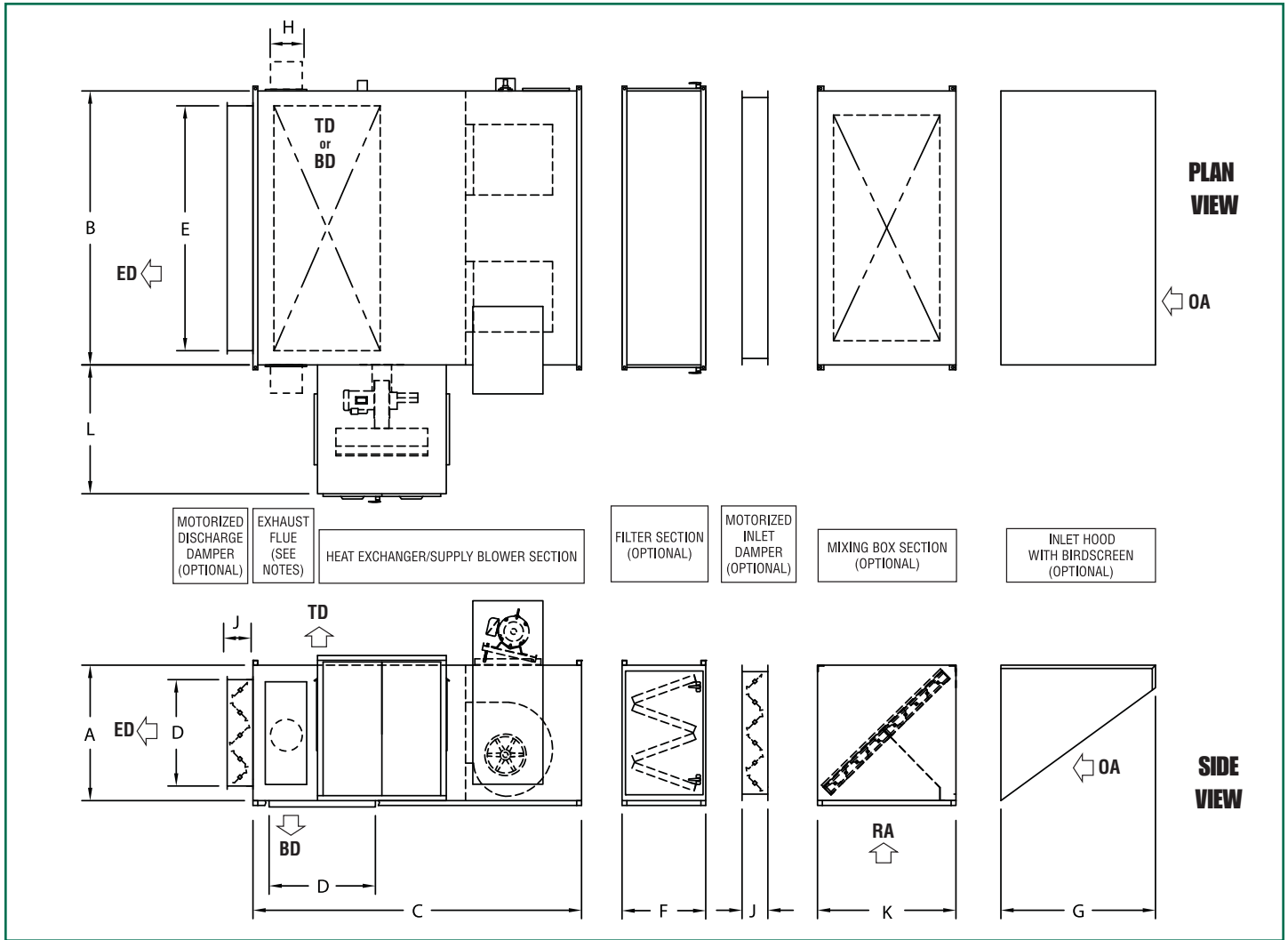

## ESTIMATED SHIPPING WEIGHTS

MODEL	HOUSINGS				FILTERS	DAMPERS		WEATHERIZING		SERVICE PLATFORM	
	HEAT EXCHANGER	BLOWER	COIL SECTION	MIX BOX	V-BANK	INLET	DISCHARGE	INLET HOOD	BLOWER H-EXCH	BLOW-ER H-EXCH	ADDTL. SECTION
<b>AIDF-35/45</b> <b>50/65/75</b>	1000 (453.0)	540 (244.6)	375 (169.9)	445 (201.6)	420 (190.3)	240 (108.7)	240 (108.7)	80 (36.2)	100 (45.3)	480 (217.4)	240 (108.7)
<b>AIDF-85/100</b>	1440 (652.3)	800 (362.4)	575 (260.5)	685 (310.3)	650 (294.5)	330 (149.5)	330 (149.5)	130 (58.9)	100 (45.3)	680 (308.0)	470 (212.9)
<b>AIDF-125</b>	1819 (824.0)	1337 (605.7)	800 (362.4)	880 (398.6)	500 (226.5)	400 (181.2)	400 (181.2)	155 (70.2)	150 (68.0)	800 (362.4)	470 (212.9)

## ESTIMATED SHIPPING WEIGHTS - BURNERS

GAS BURNER	INPUT MBH	300 - 625	626 - 938	939 - 1250	1251 - 1875	1876 - 2500	2501 - 3125	3126 - 5000
	WEIGHT	155 (70.2)	190 (86.1)	230 (104.2)	290 (131.4)	300 (135.9)	340 (154.0)	340 (154.0)
#2 OIL BURNER	INPUT GPH	2.5 - 4.5	4.6 - 6.7	6.8 - 8.9	9.0 - 13.4	13.5 - 17.9	18 - 22	22.1 - 36
	WEIGHT	125 (56.6)	125 (56.6)	220 (99.7)	220 (99.7)	310 (140.4)	360 (163.1)	385 (174.4)
COMBINATION GAS / #2 OIL BURNER	INPUT MBH	300 - 625	626 - 938	939 - 1250	1251 - 1875	1876 - 2500	2501 - 3125	3126 - 5000
	INPUT GPH	2.5 - 4.5	4.6 - 6.7	6.8 - 8.9	9.0 - 13.4	13.5 - 17.9	18 - 22	22.1 - 36
	WEIGHT	200 (90.6)	240 (108.7)	270 (122.3)	360 (163.1)	400 (181.2)	450 (203.9)	500 (226.5)

## ESTIMATED SHIPPING WEIGHTS - MOTORS

SIZE HP	.75	1	1.5	2	3	5	7.5	10	15	20	25	30	40	50	60	75
STD WEIGHT	35 (15.9)	35 (15.9)	45 (20.4)	45 (20.4)	70 (31.7)	85 (38.5)	130 (58.9)	155 (70.2)	220 (99.7)	275 (124.6)	300 (135.9)	360 (163.1)	500 (226.5)	550 (249.2)	800 (362.4)	950 (430.4)
2-SP. WEIGHT	70 (31.7)	85 (38.5)	125 (56.6)	150 (68.0)	185 (83.8)	215 (97.4)	270 (122.3)	310 (140.4)	405 (183.5)	455 (206.1)	525 (237.8)	570 (258.2)	700 (317.1)	760 (344.3)	N/A	N/A

# AIDF-SERIES UPRIGHT MODEL DIMENSIONS (150 - 450)

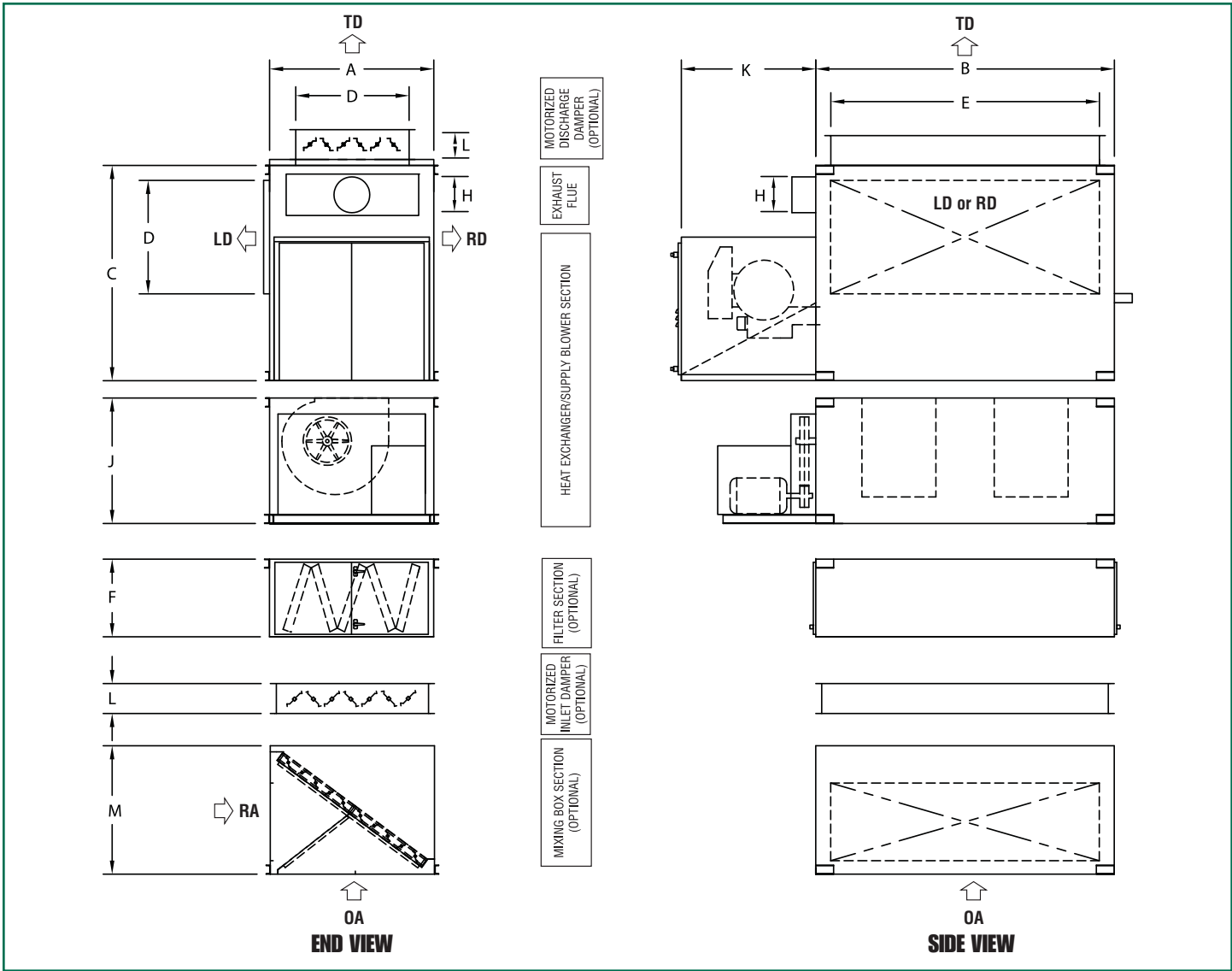

LEGEND	
TD = Top Discharge	BD = Bottom Discharge
RA = Return Air	OA = Outside Air
RD = Right Discharge	LD = Left Discharge
	ED = End Discharge

### IMPORTANT NOTES:

- Dimensions in black are in inches. Dimensions in green are in centimeters.
- Weights in black are in pounds. Weights in green are in kilograms.
- Shipping weights apply to both horizontal and upright models.
- All dimensions and weights are subject to change without notice.
- Some components may ship separately due to shipping constraints.
- Dimensions for filter sections only apply to those sections using permanent, polyester or pleated filters.
- Contact Addison for dimensions of filter sections using bag or cartridge filters.

CABINET DIMENSIONS													FILTER SECTION FILTERS	
MODEL	A	B	C	D	E	F	H	J	K	L	M	N	Qty	SIZE
<b>AIDF-150/175</b>	55 (139.7)	100 (254.0)	72 (182.9)	38 (96.5)	90 (228.6)	26 (66.0)	12 (30.5)	42 (106.7)	45 (114.3)	10 (25.4)	43 (109.2)	60 (152.4)	20	20 x 25 x 2 (50.8 x 63.5 x 5.1)
<b>AIDF-200/225</b>	55 (139.7)	116 (294.6)	72 (182.9)	38 (96.5)	100 (254.0)	26 (66.0)	12 (30.5)	55 (139.7)	45 (114.3)	10 (25.4)	43 (109.2)	60 (152.4)	10 15	20 x 20 x 2 (50.8 x 50.8 x 5.1) 20 x 25 x 2 (50.8 x 63.5 x 5.1)
<b>AIDF-250/275/300</b>	60 (152.4)	116 (294.6)	90 (228.6)	51 (129.5)	100 (254.0)	26 (66.0)	14 (35.6)	55 (139.7)	45 (114.3)	10 (25.4)	43 (109.2)	60 (152.4)	12 18	20 x 20 x 2 (50.8 x 50.8 x 5.1) 20 x 25 x 2 (50.8 x 63.5 x 5.1)
<b>AIDF-350/400/450</b>	72 (182.9)	160 (406.4)	102 (259.1)	56 (142.2)	150 (381.0)	26 (66.0)	16 (40.6)	60 (152.4)	45 (114.3)	10 (25.4)	43 (109.2)	60 (152.4)	56	20 x 20 x 2 (50.8 x 50.8 x 5.1)

# AIDF-SERIES HORIZONTAL MODEL DIMENSIONS (150 - 450)

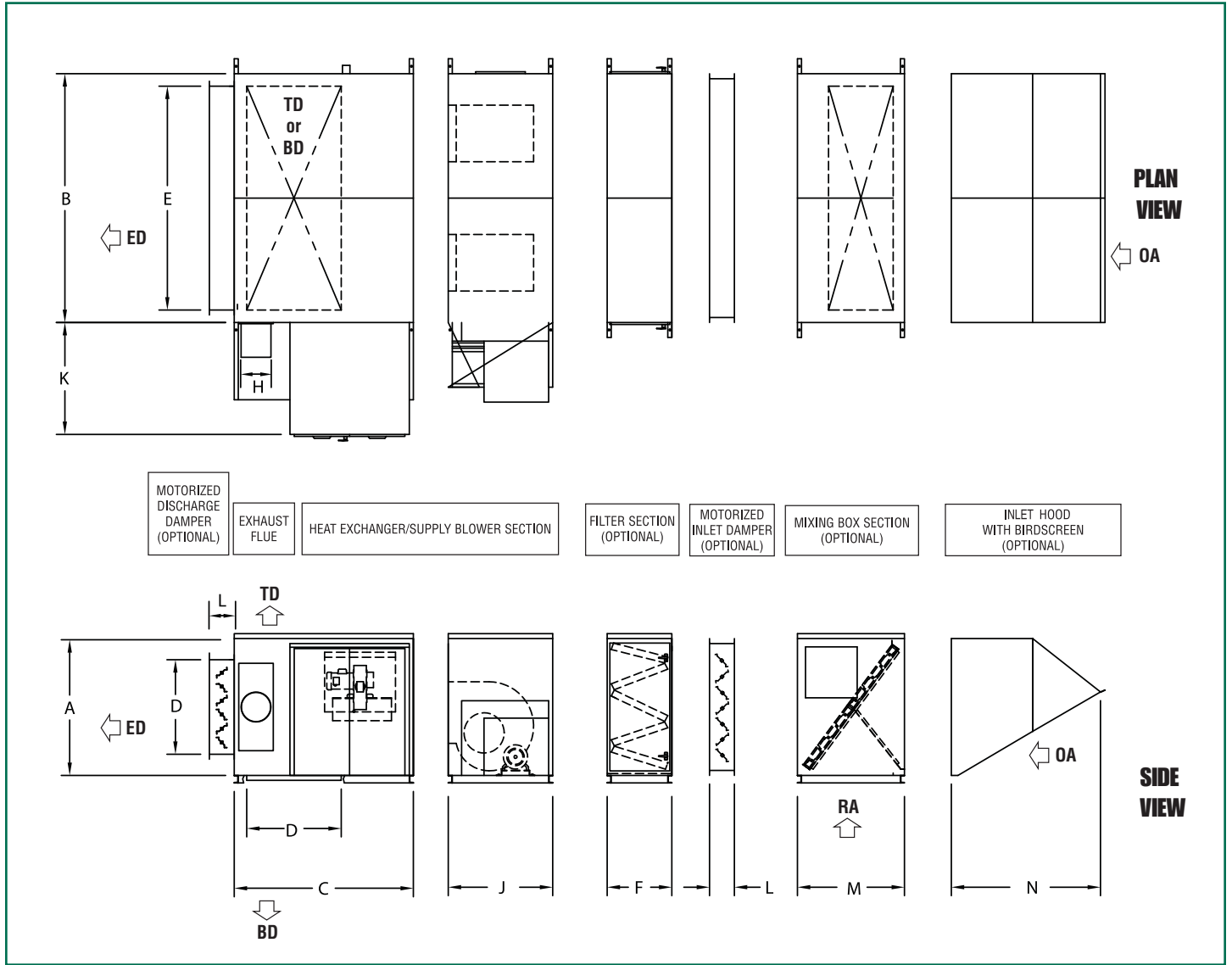

ESTIMATED SHIPPING WEIGHTS												
MODEL	HOUSINGS				FILTERS		DAMPERS		WEATHERIZING		SERVICE PLATFORM	
	HEAT EXCHANGER	BLOWER	COIL SECTION	MIX BOX	V-BANK	INLET	DIS-CHARGE	INLET HOOD	BLOWER H-EXCH	BLOWER H-EXCH	ADDTL. SECTION	
<b>AIDF-150/175</b>	2200 (996.6)	1875 (849.4)	1025 (464.3)	1075 (487.0)	950 (430.4)	470 (212.9)	470 (212.9)	180 (81.5)	200 (90.6)	940 (425.8)	470 (212.9)	
<b>AIDF-200/225 250/275</b>	3200 (1,449.6)	2500 (1,132.5)	1300 (588.9)	1325 (600.2)	1100 (498.3)	550 (249.2)	550 (249.2)	240 (108.7)	275 (124.6)	1100 (498.3)	550 (249.2)	
<b>AIDF-300/350 400/450</b>	4200 (1,902.6)	3360 (1,522.1)	1400 (634.2)	1475 (668.2)	1300 (588.9)	630 (285.4)	630 (285.4)	385 (174.4)	375 (169.9)	1260 (570.8)	630 (285.4)	

ESTIMATED SHIPPING WEIGHTS - BURNERS									
GAS BURNER	INPUT MBH	300 - 625	626 - 938	939 - 1250	1251 - 1875	1876 - 2500	2501 - 3125	3126 - 5000	
	WEIGHT	155 (70.2)	190 (86.1)	230 (104.2)	290 (131.4)	300 (135.9)	340 (154.0)	340 (154.0)	
#2 OIL BURNER	INPUT GPH	2.5 - 4.5	4.6 - 6.7	6.8 - 8.9	9.0 - 13.4	13.5 - 17.9	18 - 22	22.1 - 36	
	WEIGHT	125 (56.6)	125 (56.6)	220 (99.7)	220 (99.7)	310 (140.4)	360 (163.1)	385 (174.4)	
COMBINATION GAS / #2 OIL BURNER	INPUT MBH	300 - 625	626 - 938	939 - 1250	1251 - 1875	1876 - 2500	2501 - 3125	3126 - 5000	
	INPUT GPH	2.5 - 4.5	4.6 - 6.7	6.8 - 8.9	9.0 - 13.4	13.5 - 17.9	18 - 22	22.1 - 36	
	WEIGHT	200 (90.6)	240 (108.7)	270 (122.3)	360 (163.1)	400 (181.2)	450 (203.9)	500 (226.5)	

ESTIMATED SHIPPING WEIGHTS - MOTORS																
SIZE HP	.75	1	1.5	2	3	5	7.5	10	15	20	25	30	40	50	60	75
STD WEIGHT	35 (15.9)	35 (15.9)	45 (20.4)	45 (20.4)	70 (31.7)	85 (38.5)	130 (58.9)	155 (70.2)	220 (99.7)	275 (124.6)	300 (135.9)	360 (163.1)	500 (226.5)	550 (249.2)	800 (362.4)	950 (430.4)
2-SP. WEIGHT	70 (31.7)	85 (38.5)	125 (56.6)	150 (68.0)	185 (83.8)	215 (97.4)	270 (122.3)	310 (140.4)	405 (183.5)	455 (206.1)	525 (237.8)	570 (258.2)	700 (317.1)	760 (344.3)	N/A	N/A

# AIDF-SERIES SELECTION GUIDE

**STEP 1 - Model Identification:** Locate airflow and heat output requirements on Table A. Both criteria must fall between the minimum and maximum of the model selected.

Helpful formulas:  $\text{Btu/h output required} = \text{CFM} \times 1.08 \times \text{temperature rise}$   
 $\text{Burner input} = \text{output} / .80$

**STEP 2 - Horsepower Requirements:** First, locate airflow requirements on the side of Chart I. Draw horizontal line through it and across to the model selected in Step 1. Determine the percentage of capacity from the bar chart.

Second, refer to the bottom axis of Chart II. At the percentage determined from Chart I, draw a vertical line through that percentage, intersecting the curved lines of all the components. At the applicable intersection points, go horizontally and read the individual static pressures of each component.

Next, add all of the individual components plus the external static pressure (from the job requirement) together to determine the total static pressure. Add drive losses to this figure by multiplying total static pressure by a factor of 1.08.

Finally, refer to Tables B - H at the airflow requirement in the appropriate table for the model selected at the airflow requirement. Go horizontally until under the total static pressure required. Read the brake horsepower (BHP) and select the next highest horsepower motor for the job.

**CHART I: PERCENTAGE OF AIRFLOW CAPACITY**

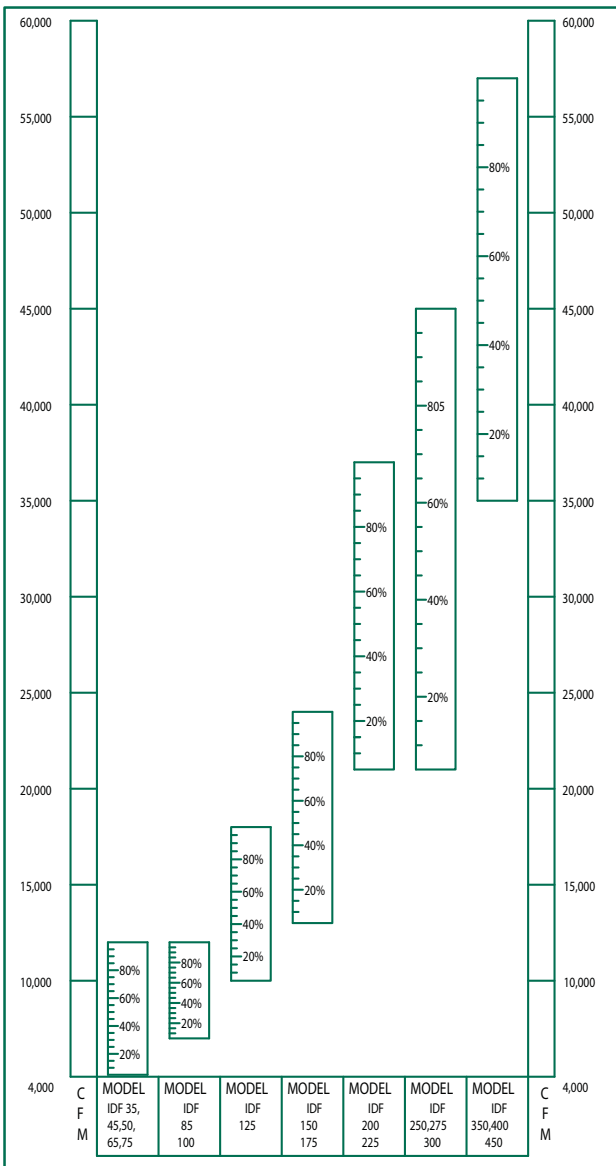

**CHART II: INTERNAL STATIC PRESSURE**

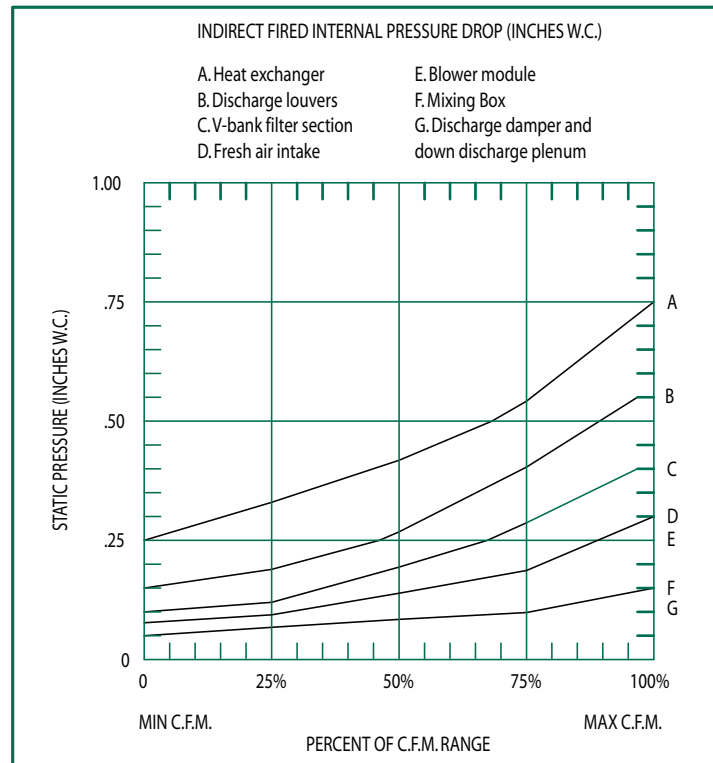

**TABLE A: MODEL NUMBER AND CAPACITY**

MODEL	OUTPUT (Btu/h) x (1000)		INPUT (MBH) (Btu/h) x (1000)		BLOWER SIZE	AIRFLOW (CFM)		FLUE SIZE	
	Max	Min	Max	Min		Max	Min	in	cm
<b>AIDF-35</b>	350	240	435	300	(1) 15 x 15	6,000	3,500	6	15.2
<b>AIDF-45</b>	450	240	560	300	(1) 15 x 15	6,000	3,500	6	15.2
<b>AIDF-50</b>	500	240	630	300	(2) 12 x 12	8,000	4,000	6	15.2
<b>AIDF-65</b>	650	520	810	640	(2) 12 x 12	8,000	4,000	6	15.2
<b>AIDF-75</b>	750	520	940	650	(2) 15 x 15	12,000	6,000	6	15.2
<b>AIDF-85</b>	850	520	1,060	650	(2) 15 x 15	12,000	6,000	8	20.3
<b>AIDF-100</b>	1,000	520	1,250	650	(2) 15 x 15	12,000	6,000	8	20.3
<b>AIDF-125</b>	1,250	560	1,565	700	(2) 18 x 18	18,000	10,000	10	25.4
<b>AIDF-150</b>	1,500	560	1,880	700	(2) 20 x 20	24,000	13,000	12	30.5
<b>AIDF-175</b>	1,750	600	2,190	750	(2) 20 x 20	24,000	13,000	12	30.5
<b>AIDF-200</b>	2,000	600	2,500	750	(2) 25 x 25	37,000	21,000	14	35.6
<b>AIDF-225</b>	2,250	600	2,800	750	(2) 25 x 25	37,000	21,000	14	35.6
<b>AIDF-250</b>	2,500	600	3,130	750	(2) 25 x 25	45,000	21,000	14	35.6
<b>AIDF-275</b>	2,750	720	3,440	900	(2) 25 x 25	45,000	21,000	14	35.6
<b>AIDF-300</b>	3,000	720	3,750	900	(2) 25 x 25	45,000	30,000	14	35.6
<b>AIDF-350</b>	3,500	720	4,380	900	(2) 30 x 30	57,000	35,000	16	40.6
<b>AIDF-400</b>	4,000	1,400	5,000	1,750	(2) 30 x 30	57,000	35,000	16	40.6
<b>AIDF-450</b>	4,500	1,400	5,600	1,750	(2) 30 x 30	57,000	35,000	16	40.6

## TABLES B - H: BLOWER MOTOR HORSEPOWER SELECTION (INCLUDES DRIVE LOSSES)

NOTE: Static pressures shown are total system pressure.

AIDF-35/45																		
TSP	.50		.75		1.00		1.25		1.50		1.75		2.00		2.25		2.50	
CFM	RPM	BHP	RPM	BHP	RPM	BHP	RPM	BHP	RPM	BHP	RPM	BHP	RPM	BHP	RPM	BHP	RPM	BHP
3,500	528	.062	623	.081	708	0.99	786	1.19	860	1.40								
4,000	548	.082	637	1.00	720	1.22	793	1.43	863	1.66	928	1.89	993	2.14				
4,500	574	1.07	654	1.27	732	1.49	805	1.73	872	1.96	935	2.22	995	2.47	1053	2.73	1110	3.00
5,000	607	1.37	675	1.57	748	1.80	819	2.00	884	2.32	945	2.58	1003	2.86	1058	3.13	1112	3.42
5,500	645	1.74	703	1.94	767	2.18	833	2.45	897	2.73	957	3.00	1014	3.30	1068	3.60	1119	3.90
6,000	686	2.18	734	2.38	791	2.62	851	2.90	913	3.20	971	3.50	1027	3.81	1079	4.13	1130	4.44

AIDF-50/65																		
TSP	.50		.75		1.00		1.25		1.50		1.75		2.00		2.25		2.50	
CFM	RPM	BHP	RPM	BHP	RPM	BHP	RPM	BHP	RPM	BHP	RPM	BHP	RPM	BHP	RPM	BHP	RPM	BHP
4,000	617	0.64	741	1.28														
4,400	627	0.76	746	1.00	852	1.24												
4,800	641	0.87	754	1.15	858	1.14	953	1.69										
5,200	656	1.03	763	1.31	864	1.59	956	1.89										
5,600	673	1.20	775	1.49	872	1.79	962	2.10	1047	2.42								
6,400	712	1.60	805	1.92	894	2.25	978	2.60	1058	2.95	1135	3.31	1208	3.67				
7,200			841	2.45	922	2.81	1001	3.19	1077	3.57	1149	3.97	1219	4.37	1286	4.77	1350	5.18
8,000					956	3.47	1029	3.87	1100	4.29	1169	4.72	1235	5.45	1300	5.59	1362	6.05

AIDF-75/85/100																		
TSP	.50		.75		1.00		1.25		1.50		1.75		2.00		2.25		2.50	
CFM	RPM	BHP	RPM	BHP	RPM	BHP	RPM	BHP	RPM	BHP	RPM	BHP	RPM	BHP	RPM	BHP	RPM	BHP
6,000	513	0.95	613	1.28														
7,000	528	1.26	624	1.61	708	1.99												
8,000	548	1.64	637	2.03	720	2.45	793	2.87	863	3.32								
9,000			654	2.53	732	2.98	805	3.45	872	3.94	935	4.42	995	4.94				
10,000			675	3.14	748	3.61	819	4.13	884	4.64	945	5.17	1003	5.72	1058	6.27	1112	6.84
11,000			703	3.88	767	4.37	833	4.90	897	5.45	957	6.02	1014	6.60	1068	7.20	1119	7.80
12,000					791	5.25	851	5.80	913	6.38	971	6.99	1027	7.62	1079	8.25	1130	8.89

AIDF-125																		
TSP	.50		.75		1.00		1.25		1.50		1.75		2.00		2.25		2.50	
CFM	RPM	BHP	RPM	BHP	RPM	BHP	RPM	BHP	RPM	BHP	RPM	BHP	RPM	BHP	RPM	BHP	RPM	BHP
10,000	463	1.97	544	2.55	617	3.13	685	3.73										
11,000	476	2.37	554	3.00	625	3.63	690	4.27	750	4.94								
12,000	489	2.83	564	3.50	633	4.19	696	4.88	755	5.59	810	6.31	863	7.04				
13,000	504	3.34	576	4.06	642	4.80	704	5.55	762	6.31	816	7.07	867	7.85	917	8.64		
14,000	521	3.92	590	4.71	653	5.49	713	6.29	769	7.09	823	7.91	872	8.74	921	9.57	970	10.42
15,000	538	4.59	603	5.41	666	6.26	724	7.10	779	7.95	830	8.82	880	9.70	926	10.55	973	11.39
16,000	557	5.33	619	6.20	678	7.09	735	7.99	788	8.90	839	9.81	887	10.66	934	11.61	975	12.55
17,000	576	6.15	636	7.08	693	8.02	747	8.97	799	9.93	848	10.87	896	11.82	941	12.77	985	13.82
18,000	596	7.07	653	8.04	708	9.03	761	10.03	810	10.97	859	12.03	905	13.08	950	14.03	993	15.16

AIDF-150/175																		
TSP	.50		.75		1.00		1.25		1.50		1.75		2.00		2.25		2.50	
CFM	RPM	BHP	RPM	BHP	RPM	BHP	RPM	BHP	RPM	BHP	RPM	BHP	RPM	BHP	RPM	BHP	RPM	BHP
13,000	397	2.32	462	2.99	522	3.72	581	4.50										
14,000	407	2.68	473	3.38	528	4.14	582	4.95	636	5.80								
15,000	419	3.08	478	3.82	533	4.60	587	5.43	637	6.32	687	7.42						
16,000	430	3.52	487	4.29	540	5.12	591	5.97	640	6.88	688	7.84						
17,000	443	4.01	497	4.83	549	5.68	597	6.57	645	7.50	691	8.48	735	9.59				
18,000	456	4.57	509	5.42	558	6.30	605	7.22	651	8.18	695	9.18	739	10.22	781	11.29	822	12.34
19,000			520	6.07	568	6.98	613	7.93	657	8.93	699	9.95	742	10.97	783	12.03	823	13.19
20,000			532	6.76	578	7.72	622	8.70	664	9.73	706	10.76	747	11.82	786	12.98	825	14.14
21,000			544	7.53	590	8.52	632	9.54	673	10.55	713	11.61	752	12.77	791	13.93	828	15.09
22,000			557	8.36	601	9.39	642	10.44	683	11.50	722	12.55	760	13.72	797	14.98	833	16.14
23,000					613	10.33	654	11.39	693	12.45	730	13.61	767	14.77	803	16.04	839	17.30
24,000					623	11.29	666	12.45	703	13.6	740	14.77	775	15.93	810	17.2	845	18.46

**TABLES B-H: BLOWER MOTOR HORSEPOWER SELECTION (INCLUDES DRIVE LOSSES) (CONT.)**

<b>AIDF-200/225/250/275/300</b>																		
TSP	.50		.75		1.00		1.25		1.50		1.75		2.00		2.25		2.50	
CFM	RPM	BHP	RPM	BHP	RPM	BHP	RPM	BHP	RPM	BHP	RPM	BHP	RPM	BHP	RPM	BHP	RPM	BHP
21,000	309	3.52	362	4.58	411	5.76												
23,000	318	4.19	368	5.22	415	6.42	460	7.92										
25,000	327	4.94	376	6.16	420	7.46	463	8.84	503	10.32								
27,000	338	5.79	384	7.09	426	8.45	467	9.89	506	11.39	544	12.98	580	14.66				
29,000			392	8.13	434	9.56	473	10.97	511	12.55	546	14.24	581	15.93	616	17.72		
31,000			402	9.31	442	10.76	480	12.34	516	13.93	551	15.61	584	17.41	617	19.20	650	21.10
33,000			413	10.55	452	12.13	487	13.72	522	15.40	556	17.20	588	18.99	620	20.89	651	22.79
35,000					461	13.61	496	15.30	530	17.09	593	18.88	593	20.68	624	20.89	654	22.79
37,000					471	15.30	505	17.09	538	18.88	599	20.68	599	22.58	629	24.58	658	26.50
39,000					481	17.09	515	18.99	546	20.78	606	22.79	606	24.69	635	26.69	663	28.80
41,000							524	20.99	555	23.00	614	24.90	614	27.01	641	29.01	669	31.23
43,000									565	25.21	622	27.32	622	29.43	649	31.54	675	33.76
45,000									575	27.75	631	29.86	631	32.07	657	34.29	683	36.50

<b>AIDF-350/400/450</b>																		
TSP	.50		.75		1.00		1.25		1.50		1.75		2.00		2.25		2.50	
CFM	RPM	BHP	RPM	BHP	RPM	BHP	RPM	BHP	RPM	BHP	RPM	BHP	RPM	BHP	RPM	BHP	RPM	BHP
35,000	265	6.54	306	8.19	344	9.93	380	11.82	415	13.82								
36,000	267	6.93	307	8.61	345	10.38	381	12.24	415	14.24								
37,000	270	7.33	310	9.04	347	10.85	382	12.77	416	14.77								
38,000	273	7.75	312	9.51	348	11.33	383	13.19	416	15.30	448	17.51						
39,000	276	8.20	314	9.98	350	11.82	384	13.72	417	15.83	448	18.04						
40,000	279	8.65	317	10.49	352	12.38	385	14.35	418	16.46	448	18.04						
41,000	282	9.13	320	10.97	354	12.92	387	14.88	419	16.99	449	19.31						
42,000	285	9.62	322	11.50	357	13.40	388	15.51	420	17.62	450	19.94	479	22.26	507	24.79		
43,000			325	12.03	359	14.09	390	16.14	421	18.25	450	20.57	480	22.99	509	25.54		
44,000			327	12.66	361	14.71	392	16.77	423	18.99	452	21.31	480	23.63	509	26.16		
45,000			330	13.19	363	15.30	395	17.48	424	19.62	453	21.94	481	24.37	509	26.90	536	29.64
46,000			333	13.83	365	16.01	397	18.18	426	20.36	455	22.68	482	25.21	510	27.75	536	30.38
47,000			335	14.45	368	16.70	399	18.89	427	21.10	456	23.53	483	25.95	510	28.49	536	31.23
48,000			339	15.19	370	17.41	401	19.62	429	21.94	457	24.27	484	26.80	511	29.33	537	32.07
49,000					373	18.14	403	20.36	431	22.74	459	25.11	485	27.64	512	30.27	537	32.92
50,000					376	18.90	405	21.21	434	23.56	460	25.95	486	28.49	513	31.45	538	33.87
51,000					379	19.62	407	21.94	436	24.41	462	26.80	488	29.43	514	32.07	539	34.82
52,000					381	20.48	410	22.79	438	25.21	464	27.75	490	30.27	515	33.02	540	35.76
53,000					384	21.31	413	23.63	440	26.16	466	28.73	492	31.23	516	33.97	541	36.71
54,000					387	22.37	415	24.58	442	27.11	468	29.69	493	32.28	518	35.03	542	37.77
55,000					390	23.04	418	25.53	444	28.06	471	30.68	494	33.38	519	36.07	543	38.82
56,000							421	26.48	447	29.01	473	31.65	497	34.29	521	37.14	544	39.98
57,000							423	27.43	449	30.07	475	32.71	499	35.47	522	38.19	545	41.04



**7050 Overland Road  
Orlando, FL 32810 U.S.A.  
Telephone: +1.407.292.4400  
Fax: +1.407.290.1329  
www.addison-hvac.com**

**Installation Code and Quarterly Inspections:** All installation and service of ADDISON™ equipment must be performed by a contractor qualified in the installation and service of equipment sold and supplied by Addison and conform to all requirements set forth in the ADDISON™ manuals and all applicable governmental authorities pertaining to the installation, service and operation of the equipment. To help facilitate optimum performance and safety, Addison recommends that a qualified contractor conduct quarterly inspections of your ADDISON™ equipment and perform service where necessary, using only replacement parts sold and supplied by Addison.

**Further Information:** Applications, engineering and detailed guidance on systems design, installation and equipment performance is available through ADDISON™ representatives. Please contact us for any further information you may require, including the Installation, Operation and Service Manual.

**These products are not for residential use.**

**This document is intended to assist licensed professionals in the exercise of their professional judgment.**

© 2009 Addison All rights reserved. No part of this work covered by the copyrights herein may be reproduced or copied in any form or by any means - graphic, electronic, or mechanical, including photocopying, recording, taping or information storage and retrieval systems - without the written permission of Addison.