



RC SERIES AIR COOLED CONDENSING UNITS

SPECIFICATIONS Rated in Accordance with ARI Standard 210/240		RC154F			
COOLING	Rated with Optional Air Handler Model	VCH/HCH154			
	Total BTUH	151,400			
	Sensible BTUH	118,600			
	EER	9.8			
ELECTRICAL	SERVICE	Voltage-Phase-Hz	208/230-3-60	460-3-60	380/415-3-50
	COMPRESSOR	Type (Qty) HP	Scroll (1) 8.0 and (1) 5.0		
		RLA	32.1/16.4	16.4/8.2	16.4/8.2
		LRA	195/124	95/59.6	86/59.6
		IPLV	10.6		
	Capacity Reduction (Standard) — (Optional)	Standard 62% — Optional 62% - 31%			
	CONDENSER FAN MOTOR(S)	Horse Power — (Qty)	1 — (2)		
		FLA (ea)	6.2	3.1	2.2
		Total CFM	11,600		
	UNIT	RLA	60.9	30.8	29.0
Unit Minimum Circuit Ampacity		69.0	29.4	33.1	
Max. Time Delay Fuse or HACR Breaker		100	50	45	
PHYSICAL DATA	CONDENSER COIL Alum. Fins on Copper Tubes	Face Area (sq.ft.)	23.1		
		Rows Deep — Fins per Inch	3 — 12 and 4 — 12		
		Suction Line OD	1 1/8 and 1 1/8		
		Liquid Line OD	1/2 and 3/8		
	WEIGHTS	Unit (lbs)	930		
		Shipping Weight (lbs)	1050		

Rated With Air Handler Model	CFM		ENTERING TEMPERATURE							
			75°F DB				80°F DB			
			59°F WB	63°F WB	67°F WB	71°F WB	59°F WB	63°F WB	67°F WB	71°F WB
VCH/HCH 154	5000	TOTAL BTUH	140,202	146,041	154,696	163,472	149,359	153,780	158,201	162,621
		SENS BTUH	135,908	115,644	94,456	73,524	149,359	141,044	119,396	98,426
		WATTS INPUT	13,103	13,196	13,383	13,558	13,277	13,280	13,411	13,576
		LVG DB/WB	50.5 48.4	54.1 53.0	58.0 57.4	61.8 61.8	53.2 47.6	54.6 52.7	58.4 57.3	62.3 61.6
	5500	TOTAL BTUH	143,867	148,331	156,447	165,191	153,067	156,588	160,109	163,631
		SENS BTUH	142,239	121,339	98,044	75,319	153,067	147,591	125,465	102,449
		WATTS INPUT	13,172	13,260	13,418	13,593	13,350	13,437	13,524	13,611
		LVG DB/WB	51.7 49.2	55.1 53.8	58.9 58.2	62.7 62.6	55.0 48.5	55.8 53.5	59.4 58.2	63.2 62.5
	6000	TOTAL BTUH	147,660	150,024	157,930	166,644	156,317	159,256	162,195	165,135
		SENS BTUH	147,660	126,498	101,539	77,043	156,317	153,797	131,017	106,380
		WATTS INPUT	13,244	13,293	13,447	13,621	13,414	13,490	13,565	13,641
		LVG DB/WB	52.9 49.9	56.0 54.6	59.8 58.9	63.5 63.3	56.6 49.2	56.9 54.1	60.3 58.9	64.1 63.2

Rated With Air Handler Model	CFM		ENTERING TEMPERATURE							
			85°F DB				90°F DB			
			59°F WB	63°F WB	67°F WB	71°F WB	59°F WB	63°F WB	67°F WB	71°F WB
VCH/HCH 154	5000	TOTAL BTUH	157,640	157,733	158,713	165,929	166,021	166,122	166,236	168,360
		SENS BTUH	157,640	157,733	145,494	124,172	166,021	166,122	166,236	149,633
		WATTS INPUT	134,40	13,442	13,464	13,607	13,598	13,600	13,603	13,624
		LVG DB/WB	56.7 46.9	56.7 52.0	58.8 57.0	62.6 61.5	60.1 46.1	60.1 51.3	60.1 56.3	63.0 61.3
	5500	TOTAL BTUH	161,632	162,944	164,256	165,568	170,300	170,404	170,523	171,180
		SENS BTUH	161,632	161,727	153,075	130,698	170,300	170,404	170,523	158,025
		WATTS INPUT	13,519	13,561	13,604	13,646	13,685	13,685	13,684	13,684
		LVG DB/WB	58.6 47.8	58.6 52.8	59.9 57.8	63.6 62.3	62.2 47.1	62.2 52.1	62.2 57.1	64.1 62.1
	6000	TOTAL BTUH	161,632	162,944	164,256	165,568	170,300	170,404	170,523	171,180
		SENS BTUH	161,632	161,727	153,075	130,698	170,300	170,404	170,523	158,025
		WATTS INPUT	13,519	13,561	13,604	13,646	13,685	13,685	13,684	13,684
		LVG DB/WB	60.3 48.5	60.3 53.5	60.9 58.4	64.4 63.0	64.0 47.9	63.9 52.9	63.9 57.8	65.1 62.7

Note: Above performance data gives gross evaporator capacity with 25' refrigerant lines and full condenser operation at 60 HZ.

Applied Research Laboratories, Inc.



Rated With Air Handler Model	CFM		ENTERING TEMPERATURE															
			75°F DB						80°F DB									
			59°F WB		63°F WB		67°F WB		71°F WB		59°F WB		63°F WB		67°F WB		71°F WB	
VCH/HCH 194	5500	TOTAL BTUH	146,243		150,979		159,295		168,392		154,673		155,376		161,219		169,585	
		SENS BTUH	140,389		123,914		100,490		77,034		154,673		146,245		128,167		105,026	
		WATTS INPUT	13,184		13,290		13,454		13,642		13,359		13,383		13,493		13,663	
		LVG DB/WB	51.9	48.9	54.6	53.5	58.5	57.9	62.3	62.3	54.5	48.2	55.9	53.2	58.9	57.9	62.7	62.2
	6000	TOTAL BTUH	148,756		152,758		160,891		169,961		158,099		158,253		163,043		171,485	
		SENS BTUH	144,822		129,244		104,198		79,138		158,099		151,379		133,902		109,656	
		WATTS INPUT	13,253		13,325		13,486		13,675		13,426		13,432		13,529		13,705	
		LVG DB/WB	53.1	49.6	55.5	54.2	59.3	58.6	63.1	63.0	56.1	48.9	57.1	53.8	59.8	58.6	63.5	62.9
	6500	TOTAL BTUH	151,421		154,931		162,531		171,304		161,132		164,174		167,216		170,258	
		SENS BTUH	149,514		134,798		108,166		80,958		161,132		155,962		140,036		113,548	
		WATTS INPUT	13,303		13,375		13,525		13,702		13,487		13,567		13,647		13,727	
		LVG DB/WB	54.2	50.2	56.2	54.9	59.9	59.2	63.7	63.6	57.5	49.6	58.3	54.5	60.5	59.2	64.2	63.5

Rated With Air Handler Model	CFM		ENTERING TEMPERATURE															
			85°F DB						90°F DB									
			59°F WB		63°F WB		67°F WB		71°F WB		59°F WB		63°F WB		67°F WB		71°F WB	
VCH/HCH 194	5500	TOTAL BTUH	163,299		163,387		165,180		171,318		172,079		17,4077		176,074		178,072	
		SENS BTUH	163,299		163,387		152,305		133,613		172,079		17,2175		170,031		158,518	
		WATTS INPUT	13,529		13,532		13,571		13,696		13,707		13,722		13,738		13,753	
		LVG DB/WB	58.1	47.5	58.1	52.5	59.9	57.4	63.0	62.0	61.7	46.8	61.6	51.9	62.0	56.9	63.9	61.7
	6000	TOTAL BTUH	166,989		167,079		168,085		173,178		175,983		176,081		176,194		178,011	
		SENS BTUH	166,989		167,079		157,983		139,866		175,983		176,081		176,194		164,150	
		WATTS INPUT	13,604		13,605		13,629		13,734		13,769		13,771		13,773		13,812	
		LVG DB/WB	59.8	48.3	59.8	53.2	61.2	58.1	63.9	62.7	63.4	47.6	63.4	52.6	63.4	57.6	65.2	62.4
	6500	TOTAL BTUH	170,256		170,348		170,552		175,368		179,491		179,591		179,704		180,804	
		SENS BTUH	170,256		170,348		162,876		146,769		179,491		179,591		179,704		169,913	
		WATTS INPUT	13,669		13,672		13,678		13,786		13,842		13,844		13,846		13,869	
		LVG DB/WB	61.3	48.9	61.3	53.9	62.3	58.7	64.6	63.3	65.0	48.3	65.0	53.3	65.0	58.2	66.3	63.0

Note: Above performance data gives gross evaporator capacity with 25' refrigerant lines and full condenser operation at 60 HZ.

Temperature	95°F	100°F	105°F	110°F	115°F
Total Capacity	1.00	.98	.95	.91	.87
Sensible Capacity	1.00	.99	.97	.95	.93
Watts	1.00	1.03	1.05	1.08	1.11
Gross EER	1.00	.95	.90	.84	.78

Capacity	At 60 HZ		At 50HZ	
	Evaporator CFM		Evaporator CFM	
Total	0.91		0.88	
Sensible	0.95		.086	
Watts	0.85		.083	

Notes: 50HZ evaporator CFM is 0.83 times full rated CFM shown above.

NOTE: Model RC154F has unequal stage capacity and requires a specific matched and circuited air handler for maximum performance. Therefore, it is not rated for use with other evaporators.

Recommended Refrigerant Line Sizes — O.D.														
Equivalent Line Length — Feet														
0 to 25					26 to 50					51 to 75				
					Hot Gas* Reheat									
					Hot Gas* Reheat									
Suction	Liquid	Hot Gas* Bypass	S	R	Suction	Liquid	Hot Gas* Bypass	S	R	Suction	Liquid	Hot Gas* Bypass	S	R
Two 1 1/8	1/2 & 3/8	5/8	5/8	3/8	Two 1 1/8	Two 1/2	5/8	5/8	3/8	Two 1 3/8	Two 1/2	5/8	5/8	3/8

- Notes:
- Line lengths are equivalent, including all fittings. Use long radius ells only.
 - Line sizes are for both vertical and horizontal runs.
 - Over 75 equivalent feet, **consult factory** for sizing recommendations.
 - Liquid line sizes and hot gas reheat return line sizes are designed to minimize system refrigerant charge.
 - Over 75 total feet, a special hot gas bypass system must be installed in the condensing unit with an oil separator. Contact Factory.
 - "S" = Hot gas supply line from RC to VC/HC; "R" = Hot gas return line from VC/HC to RC unit.
 - When condensing unit is above air handler, trap suction line at base and every 20 feet of vertical rise. Consult ASHRAE Refrigeration Handbook.

* Hot gas bypass and hot gas reheat only on lead circuit of dual circuit units.

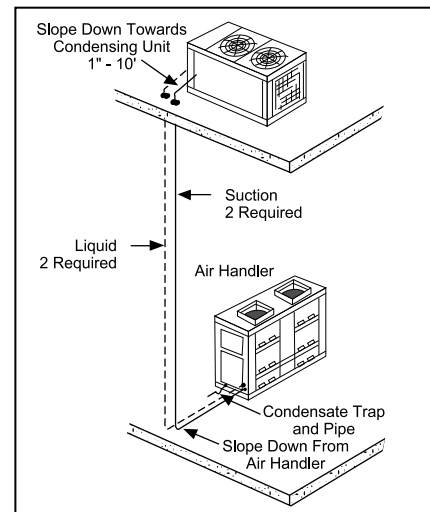
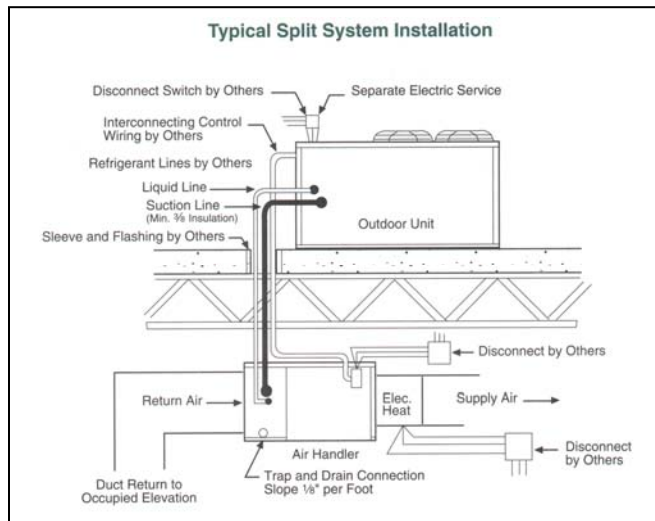
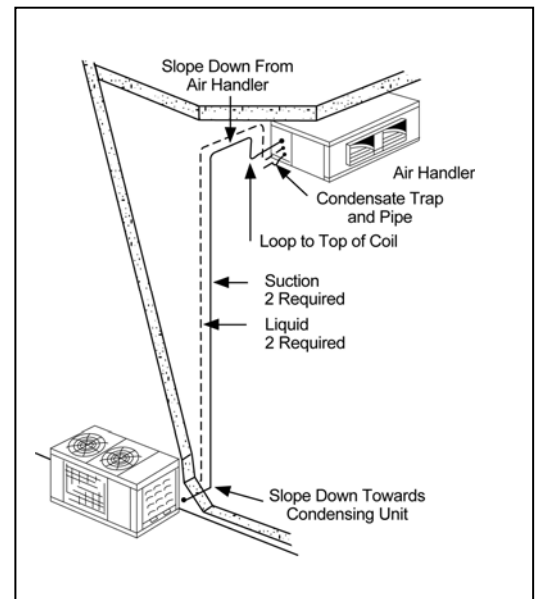
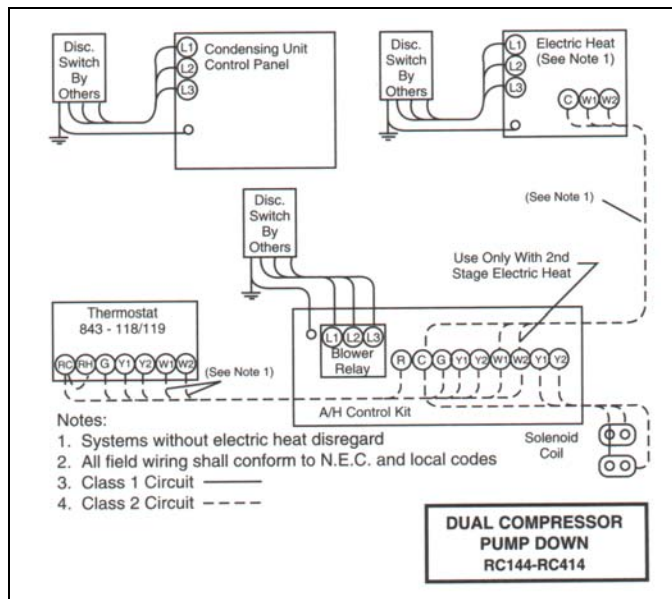

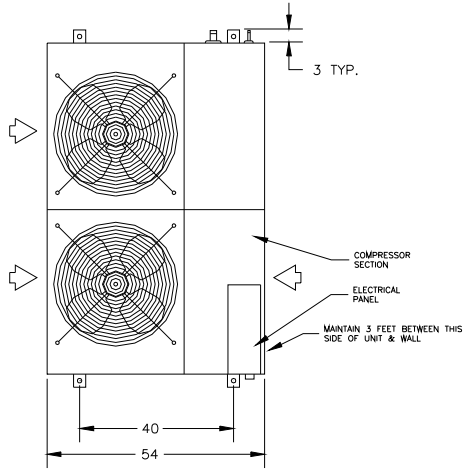

RC154

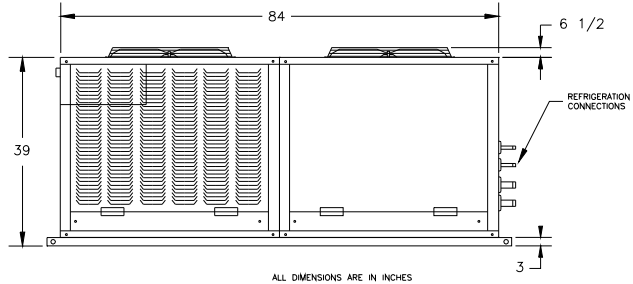
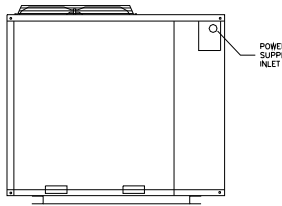

3 ft. clearance must be left for access to compressor and electrical panel

Installation Code and Annual Inspections:

All installations and service of ADDISON equipment must be performed by a contractor qualified in the installation and service of equipment sold and supplied by Addison and conform to all requirements set forth in the ADDISON manuals and all applicable governmental authorities pertaining to the installation, service and operation of the equipment. To help facilitate optimum performance and safety, Addison recommends that a qualified contractor annually inspect your ADDISON equipment and perform service where necessary, using only replacement parts sold and supplied by ADDISON.

Further Information: Applications, engineering and detailed guidance on systems design, installation and equipment performance is available through ADDISON representatives. Please contact us for any further information you may require, including the Installation, Operation and Service Manual.

These products are not for residential use.

This document is intended to assist licensed professionals in the exercise of their professional judgment.



**7050 Overland Road
Orlando, FL 32810 USA
Telephone: 407.292.4400
Fax: 407.290.1329
www.addison-hvac.com**