



RC SERIES AIR COOLED CONDENSING UNITS

SPECIFICATIONS Rated in Accordance with ARI Standard 210/240		RC314F			
COOLING	Rated with Optional Air Handler Model	VCH/HCH314			
	Total BTUH	275,300			
	Sensible BTUH	204,200			
	EER	9.5			
ELECTRICAL	SERVICE	Voltage-Phase-Hz	208/230-3-60	460-3-60	380/415-3-50
	COMPRESSOR	Type (Qty) HP	Scroll (1) 15.0 and (1) 10.0		
		RLA	45.7/42.0	24.3/19.2	27.9/19.2
		LRA	350/239	158/125	195/110
		IPLV	10.4		
	Capacity Reduction (Standard) — (Optional)	Standard 60% — Optional 60% - 30%			
	CONDENSER FAN MOTOR(S)	Horse Power — (Qty)	1 — (4)		
		FLA (ea)	6.2	3.1	2.2
		Total CFM	24,000		
	UNIT	RLA	112.5	55.9	55.9
Unit Minimum Circuit Ampacity		124.0	62.0	62.9	
Max. Time Delay Fuse or HACR Breaker		150	70	80	
PHYSICAL DATA	CONDENSER COIL Alum. Fins on Copper Tubes	Face Area (sq.ft.)	38.5		
		Rows Deep — Fins per Inch	3 — 12		
		Suction Line OD	1 5/8 and 1 3/8		
		Liquid Line OD	5/8 and 1/2		
	WEIGHTS	Unit (lbs)	1645		
Shipping Weight (lbs)		1815			

Rated With Air Handler Model	CFM		ENTERING TEMPERATURE							
			75°F DB				80°F DB			
			59°F WB	63°F WB	67°F WB	71°F WB	59°F WB	63°F WB	67°F WB	71°F WB
VCH/HCH 314	8000	TOTAL BTUH	250,755	263,497	279,569	295,429	266,243	267,437	281,804	298,041
		SENS BTUH	231,851	197,598	163,709	129,455	266,243	239,029	203,441	169,874
		WATTS INPUT	24,911	25,195	25,494	25,806	25,231	25,271	25,538	25,857
		LVG DB/WB	48.6 46.8	52.4 51.3	56.3 55.7	60.2 60.2	49.5 45.9	52.8 51.0	56.8 55.7	60.6 60.0
	9000	TOTAL BTUH	257,559	268,624	284,086	299,858	275,193	282,524	289,855	297,187
		SENS BTUH	246,761	209,230	170,840	133,496	275,193	253,928	214,977	177,859
		WATTS INPUT	25,068	25,278	25,582	25,895	25,405	25,587	25,768	25,950
		LVG DB/WB	50.0 48.0	53.8 52.5	57.7 56.9	61.4 61.4	52.0 47.1	54.3 52.2	58.2 56.9	61.9 61.2
	10000	TOTAL BTUH	265,464	272,595	287,786	303,476	282,818	288,532	294,246	299,960
		SENS BTUH	260,641	219,588	177,697	136,940	282,818	268,603	226,789	185,573
		WATTS INPUT	25,206	25,355	25,655	25,967	25,553	25,710	25,868	26,025
		LVG DB/WB	51.2 48.9	55.0 53.5	58.8 57.9	62.5 62.3	54.1 48.1	55.5 53.1	59.3 57.8	63.1 62.1

Rated With Air Handler Model	CFM		ENTERING TEMPERATURE							
			85°F DB				90°F DB			
			59°F WB	63°F WB	67°F WB	71°F WB	59°F WB	63°F WB	67°F WB	71°F WB
VCH/HCH 314	8000	TOTAL BTUH	280,502	284,816	289,130	293,445	295,093	299,407	303,721	308,036
		SENS BTUH	280,502	276,916	245,554	210,560	295,093	295,257	287,804	252,671
		WATTS INPUT	25,473	25,617	25,760	25,904	25,759	25,762	25,771	25,929
		LVG DB/WB	52.9 45.1	53.4 50.4	57.0 55.3	61.0 59.9	56.2 44.2	56.2 49.5	57.3 54.9	61.2 59.7
	9000	TOTAL BTUH	290,102	290,261	290,829	304,351	305,540	308,567	311,594	314,621
		SENS BTUH	290,102	290,261	261,809	223,288	305,540	305,713	301,967	269,820
		WATTS INPUT	25,662	25,665	25,722	25,974	25,999	26,028	26,057	26,086
		LVG DB/WB	55.5 46.3	55.5 51.4	58.5 56.5	62.4 61.1	58.9 45.5	58.9 50.7	59.4 56.0	62.7 60.8
	10000	TOTAL BTUH	298,358	300,014	301,669	303,325	314,409	316,065	317,720	319,376
		SENS BTUH	298,358	298,522	276,398	236,191	314,409	314,589	314,794	285,965
		WATTS INPUT	25,827	25,830	25,843	26,077	26,177	26,169	26,160	26,152
		LVG DB/WB	57.7 47.3	57.6 52.4	59.8 57.5	63.5 62.0	61.2 46.6	61.2 51.7	61.2 56.7	63.9 61.8

Note: Above performance data gives gross evaporator capacity with 25' refrigerant lines and full condenser operation at 60 HZ.

Applied Research Laboratories, Inc.



Listed

Rated With Air Handler Model	CFM		ENTERING TEMPERATURE															
			75°F DB						80°F DB									
			59°F WB		63°F WB		67°F WB		71°F WB		59°F WB		63°F WB		67°F WB		71°F WB	
VCH/HCH 374	10000	TOTAL BTUH	273,587		283,413		298,842		315,405		289,437		290,431		301,498		317,614	
		SENS BTUH	267,593		229,969		186,526		143,379		289,437		279,538		236,586		194,474	
		WATTS INPUT	25,482		25,662		25,970		26,310		25,803		25,820		26,012		26,341	
		LVG DB/WB	50.8	48.6	54.2	53.2	58.1	57.6	62.0	62.0	53.8	47.9	54.7	52.9	58.6	57.6	62.4	61.9
	11000	TOTAL BTUH	279,498		286,966		301,983		318,285		296,298		303,011		309,724		316,437	
		SENS BTUH	277,240		240,975		193,975		147,074		296,298		289,776		249,242		202,843	
		WATTS INPUT	25,600		25,732		26,032		26,354		25,941		26,096		26,250		26,405	
		LVG DB/WB	52.1	49.4	55.2	54.0	59.0	58.4	62.9	62.9	55.6	48.7	56.1	53.7	59.5	58.4	63.3	62.7
	12000	TOTAL BTUH	285,840		290,530		304,636		320,877		302,299		307,763		313,227		318,690	
		SENS BTUH	285,840		251,783		201,265		150,753		302,299		299,261		261,056		210,766	
		WATTS INPUT	25,722		25,806		26,084		26,407		26,062		26,186		26,311		26,435	
		LVG DB/WB	53.4	50.1	56.0	54.7	59.8	59.1	63.6	63.5	57.2	49.5	57.4	54.4	60.3	59.1	64.1	63.4

Rated With Air Handler Model	CFM		ENTERING TEMPERATURE															
			85°F DB						90°F DB									
			59°F WB		63°F WB		67°F WB		71°F WB		59°F WB		63°F WB		67°F WB		71°F WB	
VCH/HCH 374	10000	TOTAL BTUH	305,220		305,391		307,459		319,905		321,204		321,390		321,603		325,425	
		SENS BTUH	305,220		305,391		288,823		246,165		321,204		321,390		321,603		297,922	
		WATTS INPUT	26,132		26,135		26,166		26,397		26,455		26,459		26,464		26,516	
		LVG DB/WB	57.3	47.2	57.3	52.2	58.9	57.2	62.7	61.8	60.9	46.4	60.9	51.5	60.9	56.6	63.0	61.5
	11000	TOTAL BTUH	312,611		312,786		313,616		324,237		329,140		329,331		329,549		331,074	
		SENS BTUH	312,611		312,786		302,432		259,749		329,140		329,331		329,549		313,516	
		WATTS INPUT	26,283		26,286		26,301		26,485		26,622		26,625		26,630		26,647	
		LVG DB/WB	59.2	48.1	59.2	53.0	60.1	58.0	63.6	62.6	62.9	47.4	62.9	52.4	62.9	57.4	64.2	62.3
	12000	TOTAL BTUH	319,080		320,917		322,754		324,592		335,984		336,178		336,398		337,098	
		SENS BTUH	319,080		319,259		313,523		272,688		335,984		336,178		336,398		326,006	
		WATTS INPUT	26,415		26,418		26,421		26,564		26,743		26,747		26,752		26,787	
		LVG DB/WB	60.9	48.8	60.9	53.7	61.3	58.6	64.4	63.2	64.6	48.2	64.6	53.1	64.6	58.1	65.4	62.9

Note: Above performance data gives gross evaporator capacity with 25' refrigerant lines and full condenser operation at 60 HZ.

Temperature	95°F	100°F	105°F	110°F	115°F
Total Capacity	1.00	.98	.95	.91	.87
Sensible Capacity	1.00	.99	.97	.95	.93
Watts	1.00	1.03	1.05	1.08	1.11
Gross EER	1.00	.95	.90	.84	.78

Capacity	At 60 HZ	
	Evaporator CFM	At 50HZ Evaporator CFM
Total	0.91	0.88
Sensible	0.95	.086
Watts	0.85	.083

Notes: 50HZ evaporator CFM is 0.83 times full rated CFM shown above.

NOTE: Model RC314F has unequal stage capacity and requires a specific matched and circuited air handler for maximum performance. Therefore, it is not rated for use with other evaporators.

Recommended Refrigerant Line Sizes — O.D.														
Equivalent Line Length — Feet														
0 to 25					26 to 50					51 to 75				
			Hot Gas* Reheat					Hot Gas* Reheat					Hot Gas* Reheat	
Suction	Liquid	Hot Gas* Bypass	S	R	Suction	Liquid	Hot Gas* Bypass	S	R	Suction	Liquid	Hot Gas* Bypass	S	R
1 ⁵ / ₈ & 1 ³ / ₈	5/8 & 1/2	3/4	5/8	1/2	1 ⁵ / ₈ & 1 ³ / ₈	Two 5/8	3/4	3/4	1/2	Two 1 ⁵ / ₈	Two 3/4	3/4	7/8	1/2

- Notes:
- Line lengths are equivalent, including all fittings. Use long radius ells only.
 - Line sizes are for both vertical and horizontal runs.
 - Over 75 equivalent feet, **consult factory** for sizing recommendations.
 - Liquid line sizes and hot gas reheat return line sizes are designed to minimize system refrigerant charge.
 - Over 75 total feet, a special hot gas bypass system must be installed in the condensing unit with an oil separator. Contact Factory.
 - "S" = Hot gas supply line from RC to VC/HC; "R" = Hot gas return line from VC/HC to RC unit.
 - When condensing unit is above air handler, trap suction line at base and every 20 feet of vertical rise. Consult ASHRAE Refrigeration Handbook.

* Hot gas bypass and hot gas reheat only on lead circuit of dual circuit units.

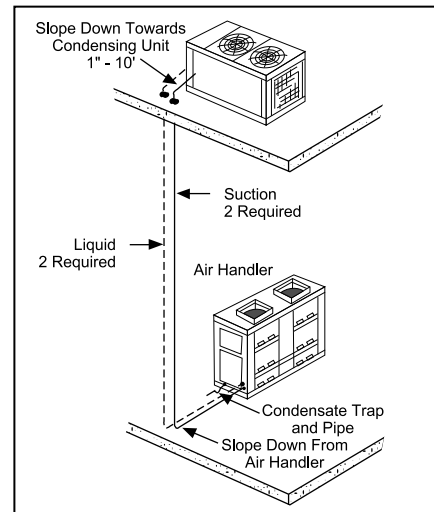
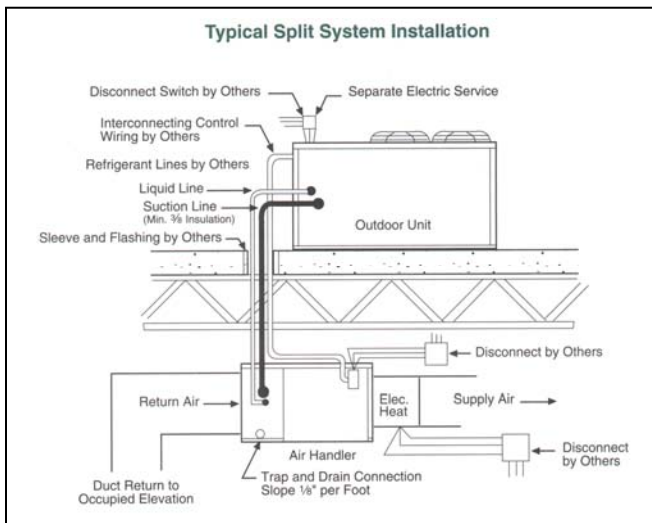
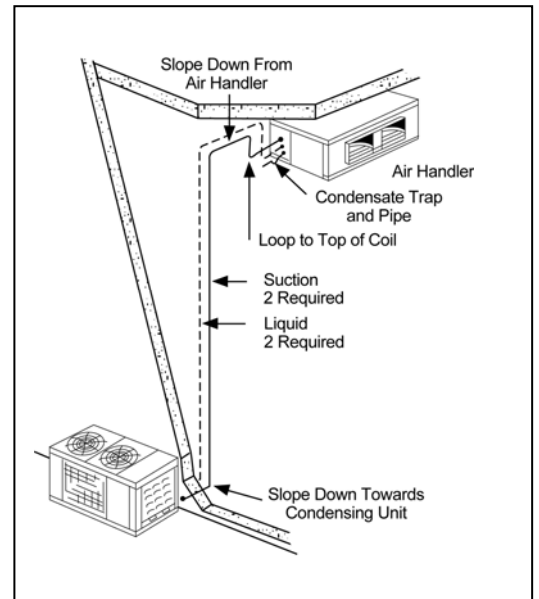
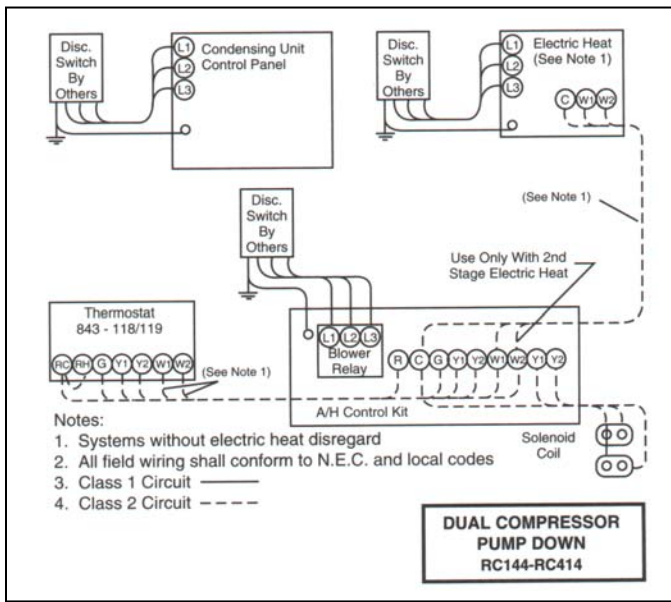

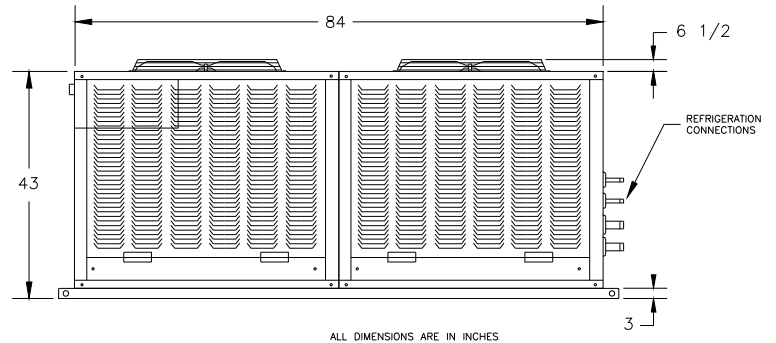
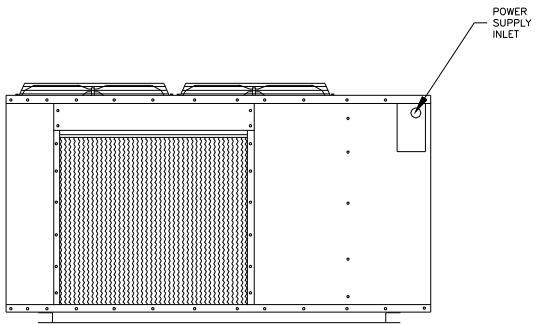
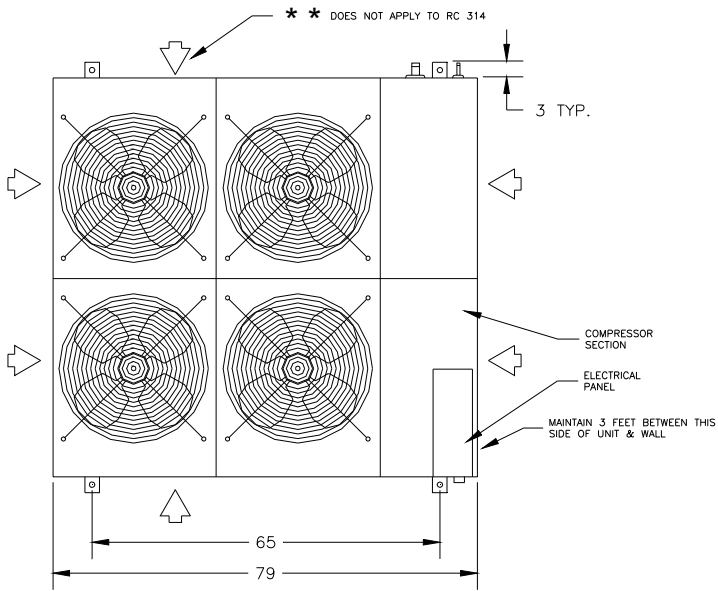

3 ft. clearance must be left for access to compressor and electrical panel

Specifications subject to change without notice.

Installation Code and Annual Inspections:

All installations and service of ADDISON equipment must be performed by a contractor qualified in the installation and service of equipment sold and supplied by Addison and conform to all requirements set forth in the ADDISON manuals and all applicable governmental authorities pertaining to the installation, service and operation of the equipment. To help facilitate optimum performance and safety, Addison recommends that a qualified contractor annually inspect your ADDISON equipment and perform service where necessary, using only replacement parts sold and supplied by ADDISON.

Further Information: Applications, engineering and detailed guidance on systems design, installation and equipment performance is available through ADDISON representatives. Please contact us for any further information you may require, including the Installation, Operation and Service Manual.

These products are not for residential use.

This document is intended to assist licensed professionals in the exercise of their professional judgment.



**7050 Overland Road
Orlando, FL 32810 USA
Telephone: 407.292.4400
Fax: 407.290.1329
www.addison-hvac.com**