



## RH SERIES AIR COOLED HEAT PUMP UNITS

SPECIFICATIONS Rated in Accordance with ARI Standard 210/240		RH124F			
PERFORMANCE	COOLING	Rated with Optional Air Handler Model	VCH/HCH124		
		Rated CFM	4,000		
	HEATING	Total BTUH	115,800		
		Sensible BTUH	87,600		
		EER	9.0		
	SERVICE	Total BTUH	116,000		
COP		3.2			
ELECTRICAL	SERVICE	Voltage-Phase-Hz	208/230-3-60	460-3-60	380/415-3-50
	COMPRESSOR	Nom. Tons — Type (Qty)	10 Ton — Hermetic (1)		
		RLA	34.6	17.3	17.3
		LRA	193	97	97
		IPLV	—		
	Standard Capacity Reduction % Full load — (Optional)		NA — (NA)		
	CONDENSER FAN MOTOR(S)	Horse Power — (Qty)	1 — (1)		
		FLA	6.2	3.1	2.2
		Total CFM	5,800		
	UNIT	RLA	40.8	20.4	19.5
Unit Minimum Circuit Ampacity		50	25	24	
Max. Time Delay Fuse or HACR Breaker		80	40	40	
PHYSICAL DATA	CONDENSER COIL Alum. Fins on Copper Tubes	Face Area (sq.ft.)	16.7		
		Rows Deep — Fins per Inch	4 — 12		
		Suction Line OD In.	1 3/8		
		Liquid Line OD In.	1/2		
	WEIGHTS	Unit (lbs)	650		
		Shipping Weight (lbs)	725		

### Cooling Rating 95°F Air on Outdoor Coil

Rated With Air Handler Model	CFM		Entering Air to Indoor Coil								
			75°F DB			80°F DB			85°F DB		
			63°F WB	67°F WB	71°F WB	63°F WB	67°F WB	71°F WB	63°F WB	67°F WB	71°F WB
VCH124 or HCH124	3500	TOTAL BTUH	109,500	116,900	124,600	111,700	117,500	125,100	117,500	119,400	125,700
		SENS BTUH	84,200	68,900	53,400	102,300	87,700	72,100	111,900	105,600	91,000
		WATTS INPUT	10,960	11,350	11,750	11,080	11,390	11,780	11,370	11,490	11,820
		LVG DB/WB	53.1/52.3	57.1/56.6	61.1/60.9	53.4/52.1	57.2/56.5	61.3/60.8	55.9/51.5	57.6/56.3	61.4/60.8
	4000	TOTAL BTUH	111,900	119,000	126,700	115,200	120,000	127,300	122,300	123,000	128,200
		SENS BTUH	90,300	73,000	55,500	109,700	94,200	76,700	116,500	114,000	98,100
		WATTS INPUT	11,090	11,460	11,860	11,250	11,520	11,900	11,620	11,680	11,960
		LVG DB/WB	54.5/53.6	58.4/57.8	62.4/62.1	55.1/53.3	58.6/57.7	62.6/62.0	58.5/52.6	59.1/57.5	62.7/62.0
	4500	TOTAL BTUH	114,100	120,800	128,400	119,000	122,200	129,000	126,300	126,400	130,300
		SENS BTUH	96,200	77,100	57,500	113,300	100,700	81,300	120,300	120,400	105,200
		WATTS INPUT	11,200	11,550	11,950	11,440	11,630	11,990	11,840	11,840	12,070
		LVG DB/WB	55.6/54.5	59.4/58.8	63.4/63.1	57.1/54.1	59.7/58.7	63.6/63.0	60.7/53.5	60.7/58.4	63.7/62.9

Note: Above performance data gives gross evaporator capacity with 25' refrigerant lines and full condenser operation at 60 HZ.

Correction Factor Multiplier for Other Ambients					
Temperature	95°F	100°F	105°F	110°F	115°F
Total Capacity	1.00	.98	.95	.91	.87
Sensible Capacity	1.00	.99	.97	.95	.93
Watts	1.00	1.03	1.05	1.08	1.11
Gross EER	1.00	.95	.90	.84	.78

50 HZ Application and Performance Multipliers		
Capacity	At 60 HZ Evaporator CFM	At 50HZ Evaporator CFM
Total	0.91	0.88
Sensible	0.95	.086
Watts	0.85	.083

Notes: 50HZ evaporator CFM is 0.83 times full rated CFM shown above.

Applied Research Laboratories, Inc.



Listed

## Heating Ratings

### 70°F Air on Coil of Indoor Air Handler Model VCH124 or HCH124

CFM	Capacity	Ambient Air on Outdoor Coil °F							
		10	17	20	30	40	47	50	60
4,000	BTUH	52,400	62,700	67,300	83,100	99,600	111,900	116,300	138,000
	Watts	6,630	7,090	7,290	7,980	8,700	9,210	9,410	10,420

Note: Heating capacities are gross capacities. For net capacities, multiply blower BHP required times 2545 BTU per BHP and add to BTUH in table. Add blower BHP times 746 Watts per BHP to Watts for total power consumption. Refer to Air Handler specification for blower BHP.

Heating Capacity Correction Multiplier To be applied to rated heating capacity to determine capacity at other than rated CFM.	CFM	Multiplier
	- 10%	0.985
	Rated	1.00
	+ 10%	1.015

Recommended Refrigerant Line Sizes — Inches O.D.						
Equivalent Line Length — Feet						
0 to 25			26 to 50		51 to 75	
Suction	Liquid	Hot Gas Bypass	Suction	Liquid	Suction	Liquid
1 3/8	1/2	3/4	1 3/8	5/8	1 3/8	5/8

- Notes:
- Line lengths are equivalent, including all fittings. Use long radius ells only.
  - Line sizes are for both vertical and horizontal runs.
  - Over 75 equivalent feet, **consult factory** for sizing recommendations.
  - Liquid line sizes are designed to minimize system refrigerant charge.
  - Hot gas bypass is typically used with the welded hermetic compressor only with an equivalent line length of 25 feet or less.
  - When condensing unit is above air handler, trap suction line at base and every 20 feet of vertical rise. Consult ASHRAE Refrigeration Handbook.

### Heat Pump Above Air Handler

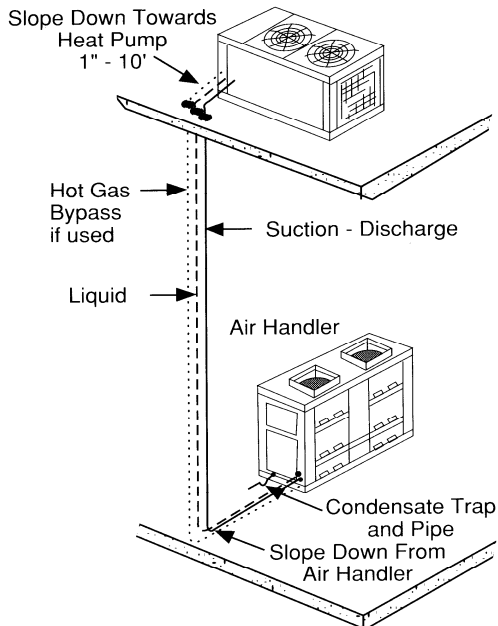

### Heat Pump Below Air Handler

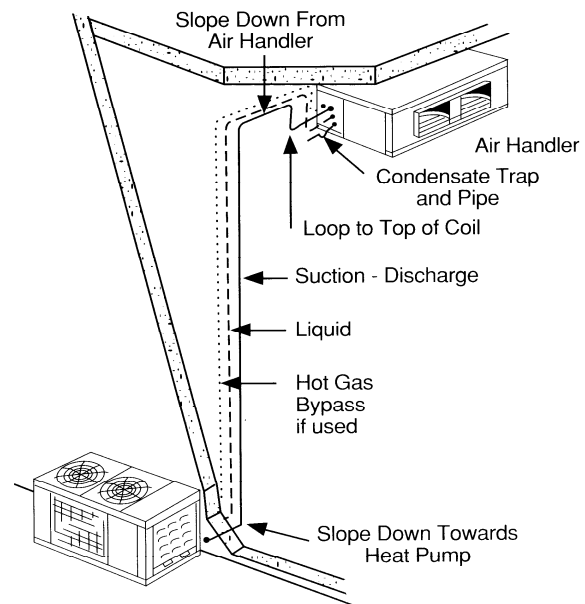

**Field Piping:** One of the most critical considerations in the installation of a split system heat pump is the proper sizing of piping so that oil will freely circulate with the refrigerant and not be trapped. In order to assure oil being carried upward in a vertical riser along with the refrigerant vapor, a velocity of 1,000 FPM must be maintained. Proper sizing is particularly important in a heat pump system because the discharge pipe on the heating cycle becomes the suction pipe in cooling and line velocities will be different in each cycle. Experience indicated 75 **equivalent** feet of pipe as the maximum practical length on heat pump installations. Pump down solenoids can not be used with heat pumps. When the air handler is installed above the compressor the vertical line must be properly sized to carry oil. The above tabulation indicates proper sizing. Each refrigerant line run underground in a chase should be insulated with 3/4" minimum thickness closed cell foamed plastic insulation. Each line must be insulated separately.

## Typical Field Wiring

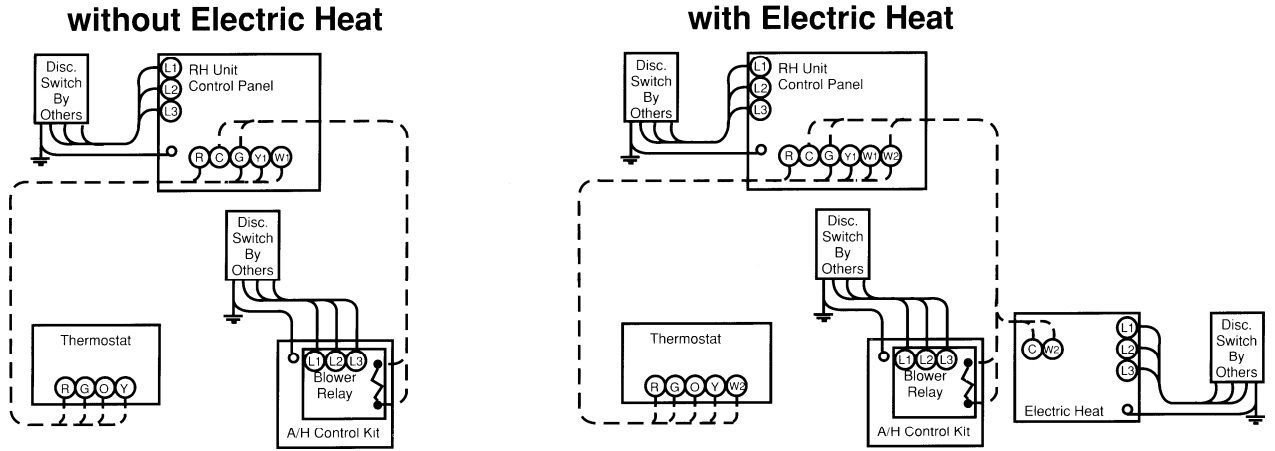

**Notes:**

All field wiring shall conform to N.E.C. and local codes

Line voltage power source \_\_\_\_\_

24 volt control circuit - - - - -

**Field Wiring**  
 The power distribution system should be sized based on the minimum circuit ampacities in this specification sheet. The heat pumps and air handlers should be fused in accordance with the maximum fuse sizes.  
 Disconnects may be optionally mounted by the factory or may be furnished and installed by the contractor. Time delay fuses should be used.  
 All field installed control wiring must be adequate to assure 24 volts to all controls.

# Dimensions

## RH124

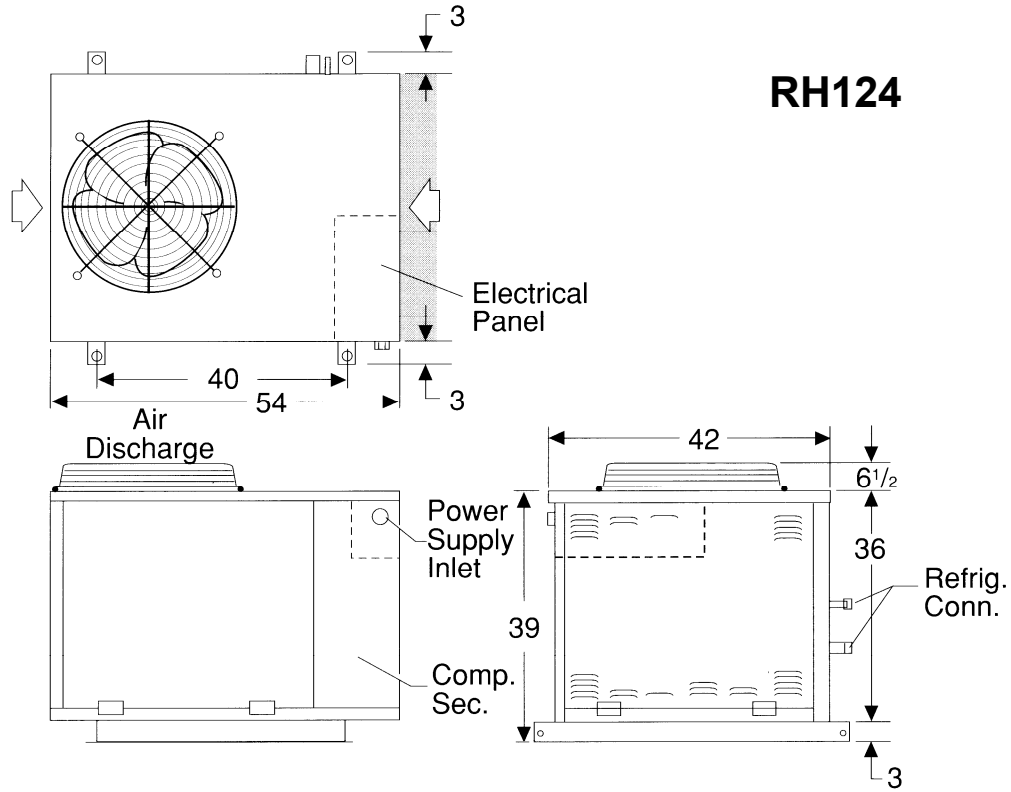

↳ Indicates air inlet to condenser (leave minimum 2' free clearance).

▨ Shaded area indicates 3' clearance must be left for access to compressor and electrical panel.

Specifications subject to change without notice.



**Installation Code and Annual Inspections:**

All installations and service of ADDISON equipment must be performed by a contractor qualified in the installation and service of equipment sold and supplied by Addison and conform to all requirements set forth in the ADDISON manuals and all applicable governmental authorities pertaining to the installation, service and operation of the equipment. To help facilitate optimum performance and safety, Addison recommends that a qualified contractor annually inspect your ADDISON equipment and perform service where necessary, using only replacement parts sold and supplied by ADDISON.

**Further Information:** Applications, engineering and detailed guidance on systems design, installation and equipment performance is available through ADDISON representatives. Please contact us for any further information you may require, including the Installation, Operation and Service Manual.

**These products are not for residential use.**

**This document is intended to assist licensed professionals in the exercise of their professional judgment.**



**7050 Overland Road  
Orlando, FL 32810 USA  
Telephone: 407.292.4400  
Fax: 407.290.1329  
[www.addison-hvac.com](http://www.addison-hvac.com)**