



## RH SERIES AIR COOLED HEAT PUMP UNITS

SPECIFICATIONS Rated in Accordance with ARI Standard 210/240		RH144F			
PERFORMANCE		Rated with Optional Air Handler Model			VCH/HCH154
		Rated CFM			5,000
	COOLING	Total BTUH			144,900
		Sensible BTUH			112,800
		EER			9.1
	HEATING	Total BTUH			147,100
COP			3.1		
ELECTRICAL	SERVICE	Voltage-Phase-Hz	208/230-3-60	460-3-60	380/415-3-50
	COMPRESSOR	(Qty) Type — Nom. Tons	(1) Hermetic — 7½ & (1) Hermetic — 4		
		RLA	27.1/15.1	14.2/7.4	14.2/7.4
		LRA	183/84	91/42	91/42
		IPLV	9.5		
	Standard Capacity Reduction % Full load — (Optional)		100-68-0 — (NA)		
	CONDENSER FAN MOTOR(S)	Horse Power — (Qty)	1 — (2)		
		FLA (ea)	6.2	3.1	2.2
		Total CFM	12,000		
	UNIT	RLA	54.6	27.8	26.0
Unit Minimum Circuit Ampacity		62	32	30	
Max. Time Delay Fuse or HACR Breaker		80	45	40	
PHYSICAL DATA	CONDENSER COIL Alum. Fins on Copper Tubes	Face Area (sq.ft.)	25.1		
		Rows Deep — Fins per Inch	3 — 12		
		(Qty) — Suction Line OD In.	(2) — 1 1/8		
		(Qty) — Liquid Line OD In.	(1) — 1/2 & (1) — 3/8		
	WEIGHTS	Unit (lbs)	910		
		Shipping Weight (lbs)	1,010		

### Cooling Rating 95°F Air on Outdoor Coil

Rated With Air Handler Model	CFM		Entering Air to Indoor Coil								
			75°F DB			80°F DB			85°F DB		
			63°F WB	67°F WB	71°F WB	63°F WB	67°F WB	71°F WB	63°F WB	67°F WB	71°F WB
VCH154 or HCH154	4000	TOTAL BTUH	133,400	143,400	153,700	135,200	143,900	154,400	140,300	145,500	154,800
		SENS BTUH	103,100	84,900	66,400	124,000	106,900	88,400	140,300	128,500	110,900
		WATTS INPUT	13,620	14,030	14,460	13,710	14,060	14,480	13,920	14,140	14,530
		LVG DB/WB	51.6/51.5	55.7/55.7	59.9/59.9	51.8/51.4	55.7/55.7	59.9/59.9	53.1/50.9	55.8/55.5	59.8/59.8
	4500	TOTAL BTUH	136,400	146,300	156,600	139,200	147,000	157,300	146,200	149,400	158,000
		SENS BTUH	109,800	89,600	68,800	132,100	114,500	94,100	146,200	137,500	118,800
		WATTS INPUT	13,740	14,140	14,560	13,870	14,180	14,600	14,150	14,290	14,640
		LVG DB/WB	52.8/52.7	56.9/56.9	61.1/61.1	53.3/52.5	56.9/56.8	61.0/61.0	55.5/51.9	57.2/56.6	61.0/61.0
	5000	TOTAL BTUH	139,000	148,600	158,900	142,700	149,700	159,700	151,200	153,000	160,800
		SENS BTUH	116,000	94,500	71,500	139,400	121,200	99,000	151,200	145,800	126,400
		WATTS INPUT	13,850	14,240	14,660	14,000	14,290	14,700	14,360	14,440	14,750
		LVG DB/WB	53.9/53.6	57.8/57.8	62.0/62.0	54.7/53.3	58.0/57.8	62.0/62.0	57.5/52.7	58.5/57.5	62.0/61.9

Note: Above performance data gives gross evaporator capacity with 25' refrigerant lines and full condenser operation at 60 HZ.

Correction Factor Multiplier for Other Ambients					
Temperature	95°F	100°F	105°F	110°F	115°F
Total Capacity	1.00	.98	.95	.91	.87
Sensible Capacity	1.00	.99	.97	.95	.93
Watts	1.00	1.03	1.05	1.08	1.11
Gross EER	1.00	.95	.90	.84	.78

50 HZ Application and Performance Multipliers		
Capacity	At 60 HZ Evaporator CFM	At 50HZ Evaporator CFM
Total	0.91	0.88
Sensible	0.95	.086
Watts	0.85	.083

Notes: 50HZ evaporator CFM is 0.83 times full rated CFM shown above.

Applied Research  
Laboratories, Inc.



## Heating Ratings

### 70°F Air on Coil of Indoor Air Handler Model VCH154 or HCH154

CFM	Capacity	Ambient Air on Outdoor Coil °F							
		10	17	20	30	40	47	50	60
5,000	BTUH	63,700	76,600	82,200	102,200	123,200	138,500	145,200	167,200
	Watts	9,130	9,670	9,920	10,730	11,620	12,280	12,570	13,590

Note: Heating capacities are gross capacities. For net capacities, multiply blower BHP required times 2545 BTU per BHP and add to BTUH in table. Add blower BHP times 746 Watts per BHP to Watts for total power consumption. Refer to Air Handler specification for blower BHP.

Heating Capacity Correction Multiplier To be applied to rated heating capacity to determine capacity at other than rated CFM.	CFM	Multiplier
	- 10%	0.985
	Rated	1.00
	+ 10%	1.015

Recommended Refrigerant Line Sizes — Inches O.D.													
Equivalent Line Length — Feet													
0 to 25				26 to 50				51 to 75					
Suction		Liquid		Hot Gas Bypass		Suction		Liquid		Suction		Liquid	
1 1/8	1 1/8	1/2	3/8	5/8	NA	1 1/8	1 1/8	1/2	1/2	1 3/8	1 1/8	1/2	1/2

- Notes:
- Line lengths are equivalent, including all fittings. Use long radius ells only.
  - Line sizes are for both vertical and horizontal runs.
  - Over 75 equivalent feet, **consult factory** for sizing recommendations.
  - Liquid line sizes are designed to minimize system refrigerant charge.
  - Hot gas bypass is typically used with the welded hermetic compressor only with an equivalent line length of 25 feet or less.
  - When condensing unit is above air handler, trap suction line at base and every 20 feet of rise. Consult ASHRAE Refrigeration Handbook.

### Heat Pump Above Air Handler

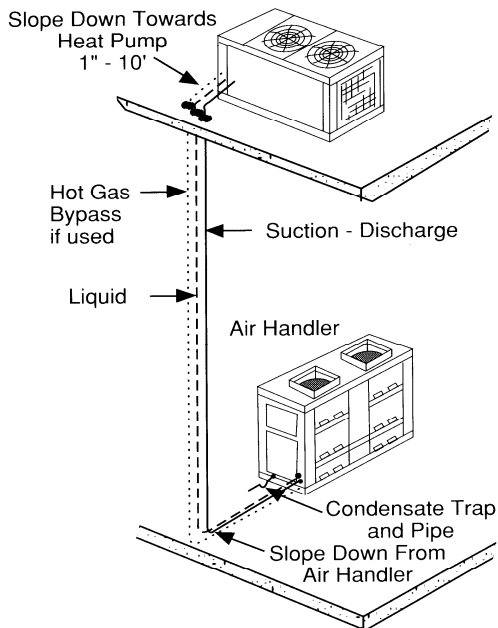

### Heat Pump Below Air Handler

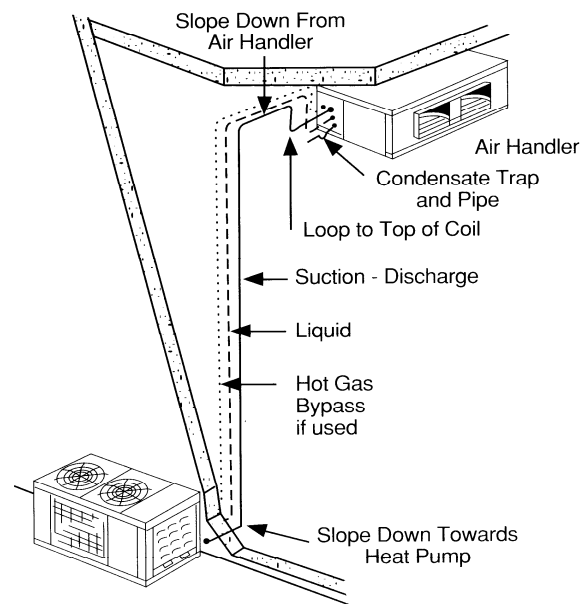

**Field Piping:** One of the most critical considerations in the installation of a split system heat pump is the proper sizing of piping so that oil will freely circulate with the refrigerant and not be trapped. In order to assure oil being carried upward in a vertical riser along with the refrigerant vapor, a velocity of 1,000 FPM must be maintained. Proper sizing is particularly important in a heat pump system because the discharge pipe on the heating cycle becomes the suction pipe in cooling and line velocities will be different in each cycle. Experience indicated 75 **equivalent** feet of pipe as the maximum practical length on heat pump installations. Pump down solenoids can not be used with heat pumps. When the air handler is installed above the compressor the vertical line must be properly sized to carry oil. The above tabulation indicates proper sizing. Each refrigerant line run underground in a chase should be insulated with 3/4" minimum thickness closed cell foamed plastic insulation. Each line must be insulated separately.

## Typical Field Wiring

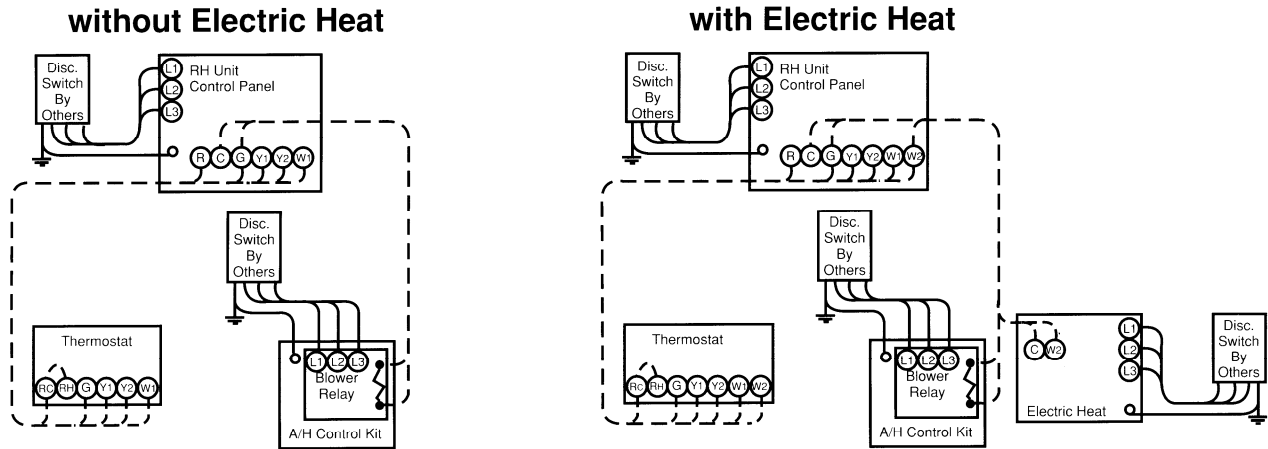

### Notes:

All field wiring shall conform to N.E.C. and local codes

Line voltage power source \_\_\_\_\_

24 volt control circuit - - - - -

### Field Wiring

The power distribution system should be sized based on the minimum circuit ampacities in this specification sheet. The heat pumps and air handlers should be fused in accordance with the maximum fuse sizes.

Disconnects may be optionally mounted by the factory or may be furnished and installed by the contractor. Time delay fuses should be used.

All field installed control wiring must be adequate to assure 24 volts to all controls.

# Dimensions

## RH144

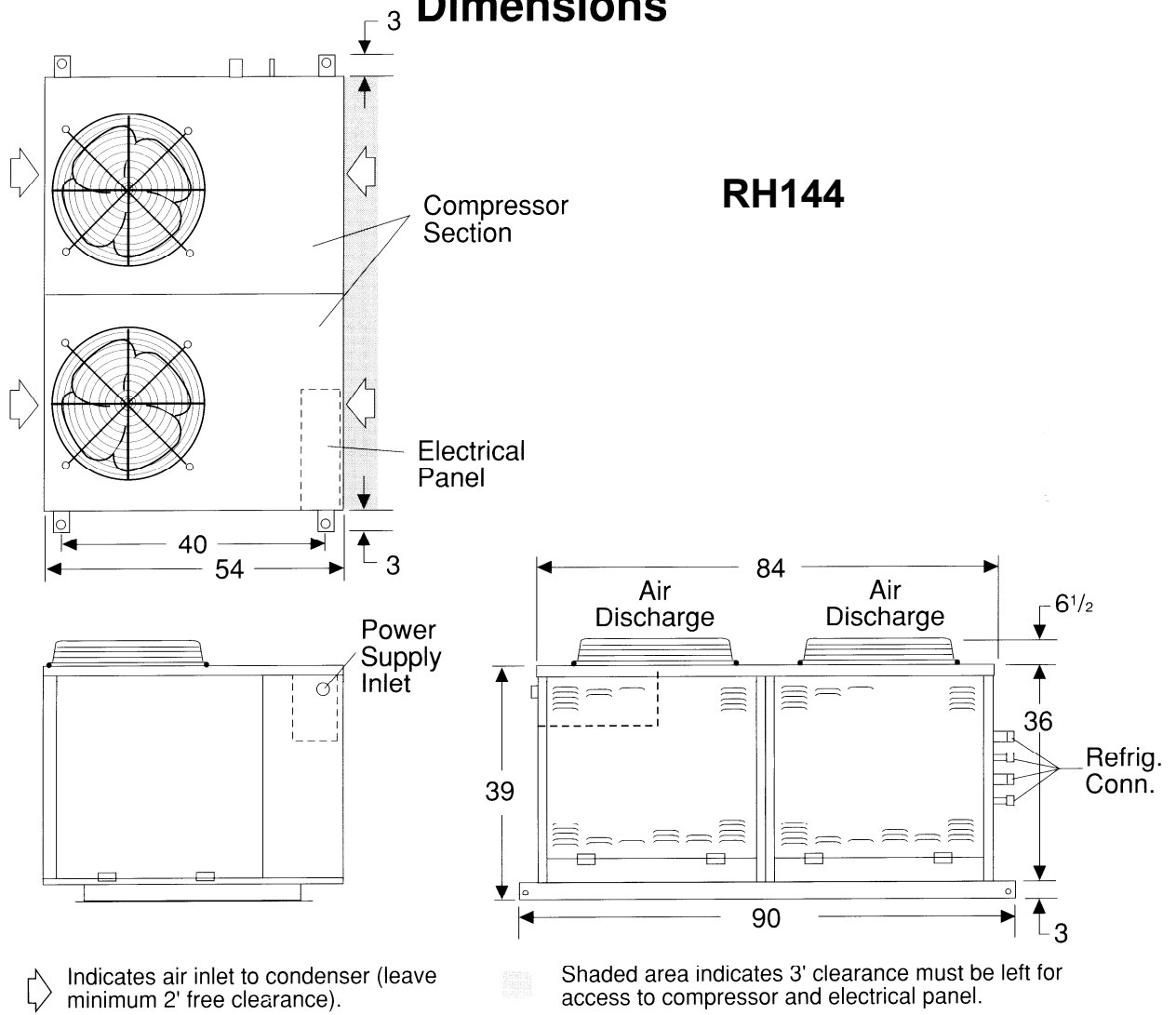

Specifications subject to change without notice.



**Installation Code and Annual Inspections:**

All installations and service of ADDISON equipment must be performed by a contractor qualified in the installation and service of equipment sold and supplied by Addison and conform to all requirements set forth in the ADDISON manuals and all applicable governmental authorities pertaining to the installation, service and operation of the equipment. To help facilitate optimum performance and safety, Addison recommends that a qualified contractor annually inspect your ADDISON equipment and perform service where necessary, using only replacement parts sold and supplied by ADDISON.

**Further Information:** Applications, engineering and detailed guidance on systems design, installation and equipment performance is available through ADDISON representatives. Please contact us for any further information you may require, including the Installation, Operation and Service Manual.

**These products are not for residential use.**

**This document is intended to assist licensed professionals in the exercise of their professional judgment.**



**7050 Overland Road  
Orlando, FL 32810 USA  
Telephone: 407.292.4400  
Fax: 407.290.1329  
[www.addison-hvac.com](http://www.addison-hvac.com)**