



RH SERIES AIR COOLED HEAT PUMP UNITS

SPECIFICATIONS Rated in Accordance with ARI Standard 210/240		RH244F				
PERFORMANCE		Rated with Optional Air Handler Model			VCH/HCH244	
		Rated CFM			8,000	
	COOLING	Total BTUH			218,000	
		Sensible BTUH			167,700	
		EER			9.5	
	HEATING	Total BTUH			215,600	
COP			3.4			
ELECTRICAL	SERVICE	Voltage-Phase-Hz	208/230-3-60	460-3-60	380/415-3-50	
	COMPRESSOR	Nom. Tons — Type (Qty)	19 Ton — Semi-Hermetic (1)			
		RLA	70	35	35	
		LRA	308	154	154	
		IPLV	12.0			
	Standard Capacity Reduction % Full load — (Optional)					NA — (100-50-0)
	CONDENSER FAN MOTOR(S)	Horse Power — (Qty)				1 — (2)
		FLA (ea)	6.2	3.1	2.2	
		Total CFM	11,600			
	UNIT	RLA	82.4	41.2	39.4	
Unit Minimum Circuit Ampacity				100		
Max. Time Delay Fuse or HACR Breaker				150		
				80		
PHYSICAL DATA	CONDENSER COIL Alum. Fins on Copper Tubes	Face Area (sq.ft.)				25.1
		Rows Deep — Fins per Inch				4 — 12
		Suction Line OD In.				1 5/8
		Liquid Line OD In.				5/8
	WEIGHTS	Unit (lbs)				1,190
		Shipping Weight (lbs)				1,290

Cooling Rating 95°F Air on Outdoor Coil

Rated With Air Handler Model	CFM		Entering Air to Indoor Coil								
			75°F DB			80°F DB			85°F DB		
			63°F WB	67°F WB	71°F WB	63°F WB	67°F WB	71°F WB	63°F WB	67°F WB	71°F WB
VCH244 or HCH244	7000	TOTAL BTUH	208,700	221,800	235,500	214,000	223,300	237,000	226,800	227,900	238,400
		SENS BTUH	162,100	131,400	100,900	197,900	168,600	137,600	216,000	206,200	175,100
		WATTS INPUT	19,530	20,050	20,590	19,740	20,120	20,650	20,250	20,300	20,720
		LVG DB/WB	53.9/52.9	57.9/57.2	61.9/61.5	54.3/52.6	58.1/57.1	62.1/61.4	56.9/51.9	58.2/56.9	62.3/61.3
	7500	TOTAL BTUH	211,000	224,000	237,400	218,300	225,700	239,200	231,300	231,400	240,800
		SENS BTUH	167,900	135,900	102,800	208,000	174,900	142,500	220,300	213,200	181,900
		WATTS INPUT	19,620	20,090	20,660	19,910	20,210	20,690	20,430	20,440	20,810
		LVG DB/WB	54.6/53.5	58.5/57.8	62.5/62.1	54.8/53.0	58.8/57.7	62.7/62.0	58.3/52.5	59.2/57.4	63.0/61.9
	8000	TOTAL BTUH	213,100	225,800	239,400	222,200	227,900	241,000	235,500	235,600	243,000
		SENS BTUH	174,700	139,800	105,300	211,600	181,400	146,900	224,300	224,400	188,600
		WATTS INPUT	19,700	20,160	20,690	20,030	20,270	20,770	20,590	20,590	20,900
		LVG DB/WB	55.1/54.0	59.1/58.4	63.0/62.6	56.0/53.6	59.4/58.3	63.3/62.6	59.5/53.0	59.5/57.9	63.6/62.5

Note: Above performance data gives gross evaporator capacity with 25' refrigerant lines and full condenser operation at 60 HZ.

Correction Factor Multiplier for Other Ambients					
Temperature	95°F	100°F	105°F	110°F	115°F
Total Capacity	1.00	.98	.95	.91	.87
Sensible Capacity	1.00	.99	.97	.95	.93
Watts	1.00	1.03	1.05	1.08	1.11
Gross EER	1.00	.95	.90	.84	.78

50 HZ Application and Performance Multipliers		
Capacity	At 60 HZ Evaporator CFM	At 50HZ Evaporator CFM
Total	0.91	0.88
Sensible	0.95	.086
Watts	0.85	.083

Notes: 50HZ evaporator CFM is 0.83 times full rated CFM shown above.

Applied Research Laboratories, Inc.



Listed

Heating Ratings 70°F Air on Coil of Indoor Air Handler Model VCH244 or HCH244

CFM	Capacity	Ambient Air on Outdoor Coil °F							
		10	17	20	30	40	47	50	60
8,000	BTUH	111,800	126,500	133,300	157,700	184,900	205,200	214,200	245,600
	Watts	11,610	12,510	12,880	14,090	15,230	16,020	16,360	17,590

Note: Heating capacities are gross capacities. For net capacities, multiply blower BHP required times 2545 BTU per BHP and add to BTUH in table. Add blower BHP times 746 Watts per BHP to Watts for total power consumption. Refer to Air Handler specification for blower BHP.

Heating Capacity Correction Multiplier To be applied to rated heating capacity to determine capacity at other than rated CFM.	CFM	Multiplier
	- 10%	0.985
	Rated	1.00
	+ 10%	1.015

Recommended Refrigerant Line Sizes — Inches O.D.						
Equivalent Line Length — Feet						
0 to 25			26 to 50		51 to 75	
Suction	Liquid	Hot Gas Bypass	Suction	Liquid	Suction	Liquid
1 5/8	5/8	NA	1 5/8	3/4	2 1/8	3/4

- Notes:
- Line lengths are equivalent, including all fittings. Use long radius ells only.
 - Line sizes are for both vertical and horizontal runs.
 - Over 75 equivalent feet, **consult factory** for sizing recommendations.
 - Liquid line sizes are designed to minimize system refrigerant charge.
 - Hot gas bypass is typically used with the welded hermetic compressor only with an equivalent line length of 25 feet or less.

Heat Pump Above Air Handler

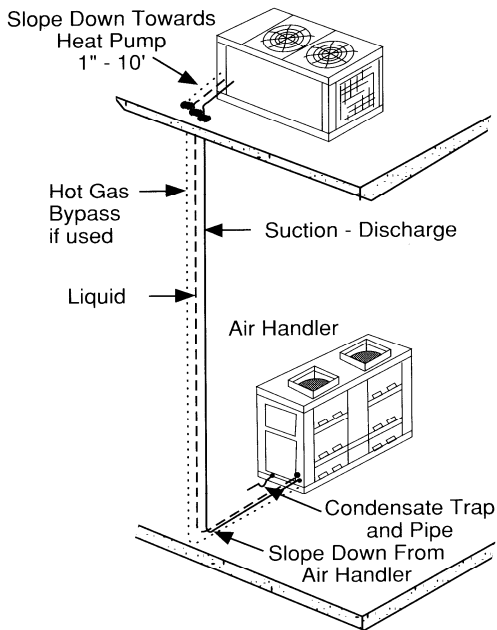

Heat Pump Below Air Handler

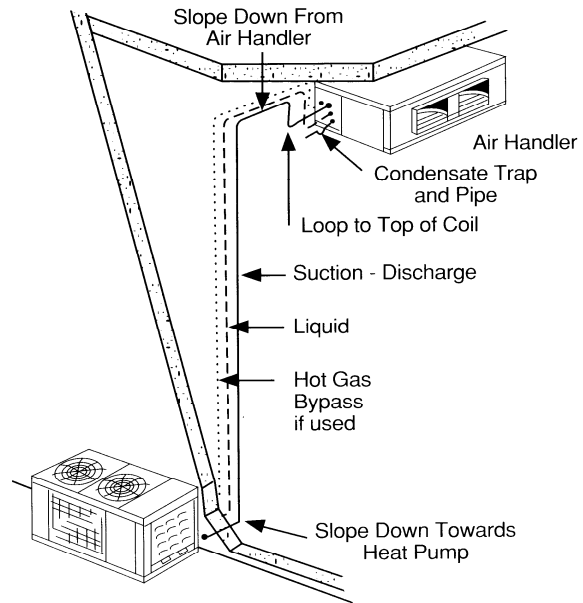

Field Piping: One of the most critical considerations in the installation of a split system heat pump is the proper sizing of piping so that oil will freely circulate with the refrigerant and not be trapped. In order to assure oil being carried upward in a vertical riser along with the refrigerant vapor, a velocity of 1,000 FPM must be maintained. Proper sizing is particularly important in a heat pump system because the discharge pipe on the heating cycle becomes the suction pipe in cooling and line velocities will be different in each cycle. Experience indicated 75 **equivalent** feet of pipe as the maximum practical length on heat pump installations. Pump down solenoids can not be used with heat pumps. When the air handler is installed above the compressor the vertical line must be properly sized to carry oil. The above tabulation indicates proper sizing. Each refrigerant line run underground in a chase should be insulated with 3/4" minimum thickness closed cell foamed plastic insulation. Each line must be insulated separately.

Typical Field Wiring

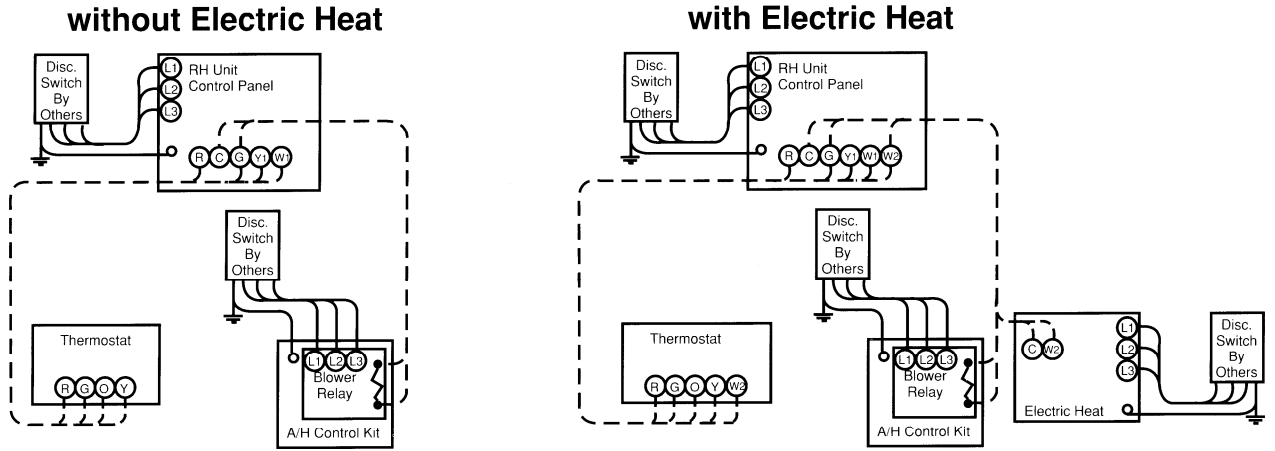

Notes:

All field wiring shall conform to N.E.C. and local codes

Line voltage power source _____

24 volt control circuit - - - - -

Field Wiring
 The power distribution system should be sized based on the minimum circuit ampacities in this specification sheet. The heat pumps and air handlers should be fused in accordance with the maximum fuse sizes.
 Disconnects may be optionally mounted by the factory or may be furnished and installed by the contractor. Time delay fuses should be used.
 All field installed control wiring must be adequate to assure 24 volts to all controls.

Dimensions

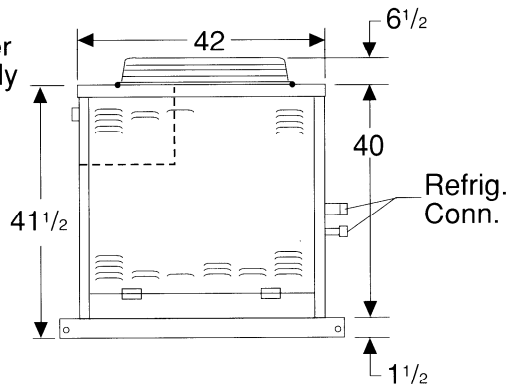
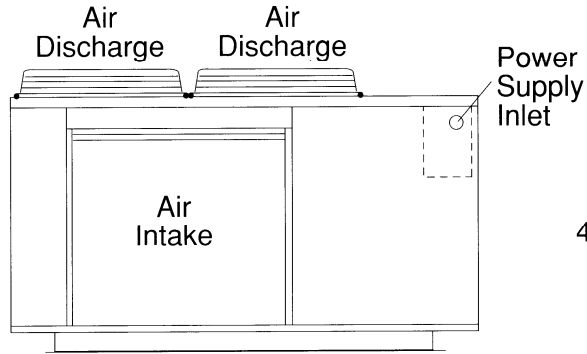
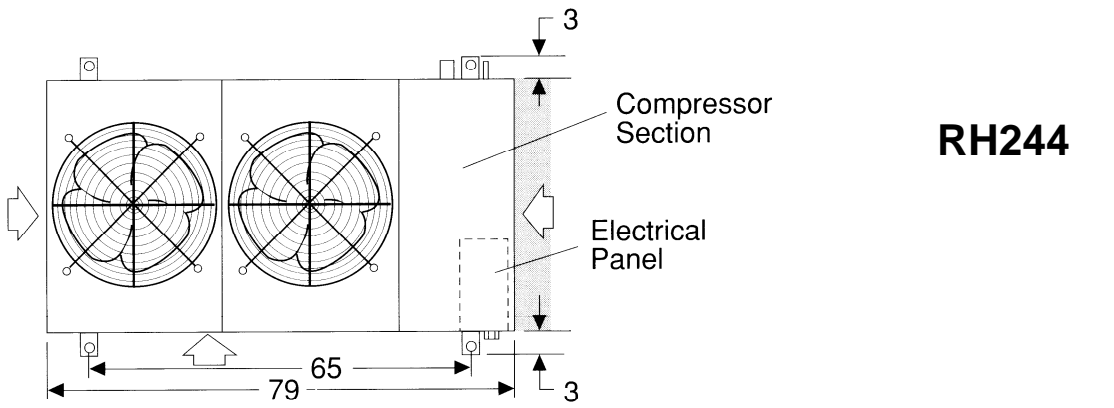

↔ Indicates air inlet to condenser (leave minimum 2' free clearance).

■ Shaded area indicates 3' clearance must be left for access to compressor and electrical panel.

Specifications subject to change without notice.

Installation Code and Annual Inspections:

All installations and service of ADDISON equipment must be performed by a contractor qualified in the installation and service of equipment sold and supplied by Addison and conform to all requirements set forth in the ADDISON manuals and all applicable governmental authorities pertaining to the installation, service and operation of the equipment. To help facilitate optimum performance and safety, Addison recommends that a qualified contractor annually inspect your ADDISON equipment and perform service where necessary, using only replacement parts sold and supplied by ADDISON.

Further Information: Applications, engineering and detailed guidance on systems design, installation and equipment performance is available through ADDISON representatives. Please contact us for any further information you may require, including the Installation, Operation and Service Manual.

These products are not for residential use.

This document is intended to assist licensed professionals in the exercise of their professional judgment.



**7050 Overland Road
Orlando, FL 32810 USA
Telephone: 407.292.4400
Fax: 407.290.1329
www.addison-hvac.com**