



## RH SERIES AIR COOLED HEAT PUMP UNITS

SPECIFICATIONS Rated in Accordance with ARI Standard 210/240		RH374F				
PERFORMANCE		Rated with Optional Air Handler Model			VCH/HCH374	
		Rated CFM			13,000	
	COOLING	Total BTUH			362,600	
		Sensible BTUH			279,200	
		EER			9.8	
	HEATING	Total BTUH			352,300	
COP			3.3			
ELECTRICAL	SERVICE	Voltage-Phase-Hz	208/230-3-60	460-3-60	380/415-3-50	
	COMPRESSOR	(Qty) Type	Scroll (1) tandem configured			
		RLA (ea)	52.6	23.8	23.8	
		LRA (ea)	425	187	187	
		IPLV	10.0			
	Standard Capacity Reduction % Full load — (Optional)					100-50-0 — (100-50-30-0)
	CONDENSER FAN MOTOR(S)	Horse Power — (Qty)				1 — (4)
		FLA (ea)	6.2	3.1	2.2	
		Total CFM				24,000
	UNIT	RLA	130.0	60.0	56.4	
Unit Minimum Circuit Ampacity				143.2		
Max. Time Delay Fuse or HACR Breaker				175		
PHYSICAL DATA	CONDENSER COIL Alum. Fins on Copper Tubes	Face Area (sq.ft.)				50.1
		Rows Deep — Fins per Inch				3 — 12
		(Qty) — Suction Line OD In.				(2) — 1 5/8
		(Qty) — Liquid Line OD In.				(2) — 5/8
	WEIGHTS	Unit (lbs)				2,110
		Shipping Weight (lbs)				2,280

### Cooling Rating 95°F Air on Outdoor Coil

Rated With Air Handler Model	CFM		Entering Air to Indoor Coil								
			75°F DB			80°F DB			85°F DB		
			63°F WB	67°F WB	71°F WB	63°F WB	67°F WB	71°F WB	63°F WB	67°F WB	71°F WB
VCH374 or HCH374	11000	TOTAL BTUH	345,200	367,800	391,400	351,700	369,600	393,100	369,600	375,100	395,100
		SENS BTUH	265,500	217,000	167,500	321,800	275,500	226,300	352,000	331,900	286,600
		WATTS INPUT	31,700	32,500	33,350	32,000	32,630	33,430	32,640	32,840	33,500
		LVG DB/WB	53.1/52.3	57.1/56.6	61.2/60.8	53.4/52.0	57.2/56.5	61.3/60.8	55.9/51.4	57.6/56.3	61.3/60.7
	12000	TOTAL BTUH	350,100	372,200	395,800	358,900	374,600	397,800	379,400	382,300	400,300
		SENS BTUH	277,700	225,300	171,700	336,400	288,600	236,300	361,400	349,900	300,800
		WATTS INPUT	31,900	32,650	33,500	32,210	32,800	33,530	32,970	33,080	33,640
		LVG DB/WB	54.0/53.1	57.9/57.4	62.0/61.7	54.5/52.8	58.1/57.3	62.1/61.6	57.6/52.2	58.5/57.1	62.2/61.6
	13000	TOTAL BTUH	354,100	376,000	399,500	366,000	379,000	401,400	388,200	389,000	404,900
		SENS BTUH	290,000	233,500	175,800	348,500	301,600	244,800	369,700	364,200	314,800
		WATTS INPUT	32,070	32,780	33,630	32,450	32,950	33,720	33,270	33,310	33,790
		LVG DB/WB	54.7/53.8	58.7/58.1	62.7/62.4	55.6/53.5	58.9/58.0	62.9/62.3	59.1/52.8	59.5/57.8	63.0/62.2

Note: Above performance data gives gross evaporator capacity with 25' refrigerant lines and full condenser operation at 60 HZ.

Correction Factor Multiplier for Other Ambients					
Temperature	95°F	100°F	105°F	110°F	115°F
Total Capacity	1.00	.98	.95	.91	.87
Sensible Capacity	1.00	.99	.97	.95	.93
Watts	1.00	1.03	1.05	1.08	1.11
Gross EER	1.00	.95	.90	.84	.78

50 HZ Application and Performance Multipliers		
Capacity	At 60 HZ Evaporator CFM	At 50HZ Evaporator CFM
Total	0.91	0.88
Sensible	0.95	.086
Watts	0.85	.083

Notes: 50HZ evaporator CFM is 0.83 times full rated CFM shown above.

Applied Research  
Laboratories, Inc.



## Heating Ratings

### 70°F Air on Coil of Indoor Air Handler Model VCH374 or HCH374

CFM	Capacity	Ambient Air on Outdoor Coil °F							
		10	17	20	30	40	47	50	60
13,000	BTUH	180,900	204,800	215,900	256,400	301,200	334,900	349,800	398,500
	Watts	19,540	21,040	21,650	23,580	25,420	26,690	27,240	29,400

Note: Heating capacities are gross capacities. For net capacities, multiply blower BHP required times 2545 BTU per BHP and add to BTUH in table. Add blower BHP times 746 Watts per BHP to Watts for total power consumption. Refer to Air Handler specification for blower BHP.

Heating Capacity Correction Multiplier To be applied to rated heating capacity to determine capacity at other than rated CFM.	CFM	Multiplier
	- 10%	0.985
	Rated	1.00
	+ 10%	1.015

Recommended Refrigerant Line Sizes — Inches OD													
Equivalent Line Length — Feet													
0 to 25				26 to 50				51 to 75					
Suction		Liquid		Hot Gas Bypass		Suction		Liquid		Suction		Liquid	
1 5/8	1 5/8	5/8	5/8	NA	NA	1 5/8	1 5/8	5/8	5/8	1 5/8	1 5/8	3/8	3/8

- Notes:
- Line lengths are equivalent, including all fittings. Use long radius ells only.
  - Line sizes are for both vertical and horizontal runs.
  - Over 75 equivalent feet, **consult factory** for sizing recommendations.
  - Liquid line sizes are designed to minimize system refrigerant charge.
  - Hot gas bypass is typically used with the welded hermetic compressor only with an equivalent line length of 25 feet or less.
  - When condensing unit is above air handler, trap suction line at base and every 20 feet of vertical rise. Consult ASHRAE Refrigeration Handbook.

### Heat Pump Above Air Handler

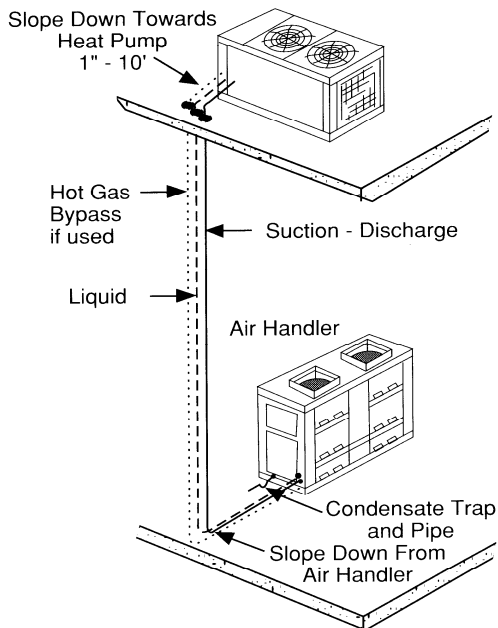

### Heat Pump Below Air Handler

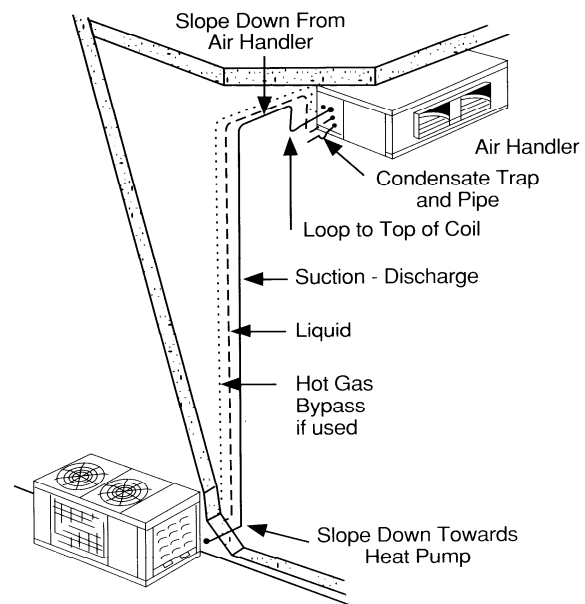

**Field Piping:** One of the most critical considerations in the installation of a split system heat pump is the proper sizing of piping so that oil will freely circulate with the refrigerant and not be trapped. In order to assure oil being carried upward in a vertical riser along with the refrigerant vapor, a velocity of 1,000 FPM must be maintained. Proper sizing is particularly important in a heat pump system because the discharge pipe on the heating cycle becomes the suction pipe in cooling and line velocities will be different in each cycle. Experience indicated 75 **equivalent** feet of pipe as the maximum practical length on heat pump installations. Pump down solenoids can not be used with heat pumps. When the air handler is installed above the compressor the vertical line must be properly sized to carry oil. The above tabulation indicates proper sizing. Each refrigerant line run underground in a chase should be insulated with 3/4" minimum thickness closed cell foamed plastic insulation. Each line must be insulated separately.

## Typical Field Wiring

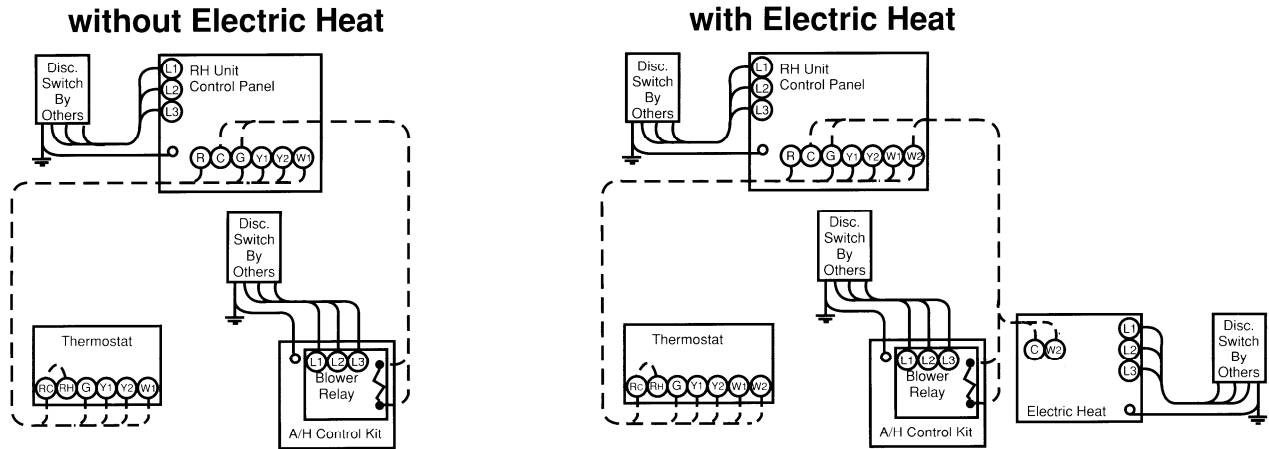

**Notes:**

All field wiring shall conform to N.E.C. and local codes

Line voltage power source \_\_\_\_\_

24 volt control circuit - - - - -

**Field Wiring**  
 The power distribution system should be sized based on the minimum circuit ampacities in this specification sheet. The heat pumps and air handlers should be fused in accordance with the maximum fuse sizes. Disconnects may be optionally mounted by the factory or may be furnished and installed by the contractor. Time delay fuses should be used.  
 All field installed control wiring must be adequate to assure 24 volts to all controls.

# Dimensions

## RH374

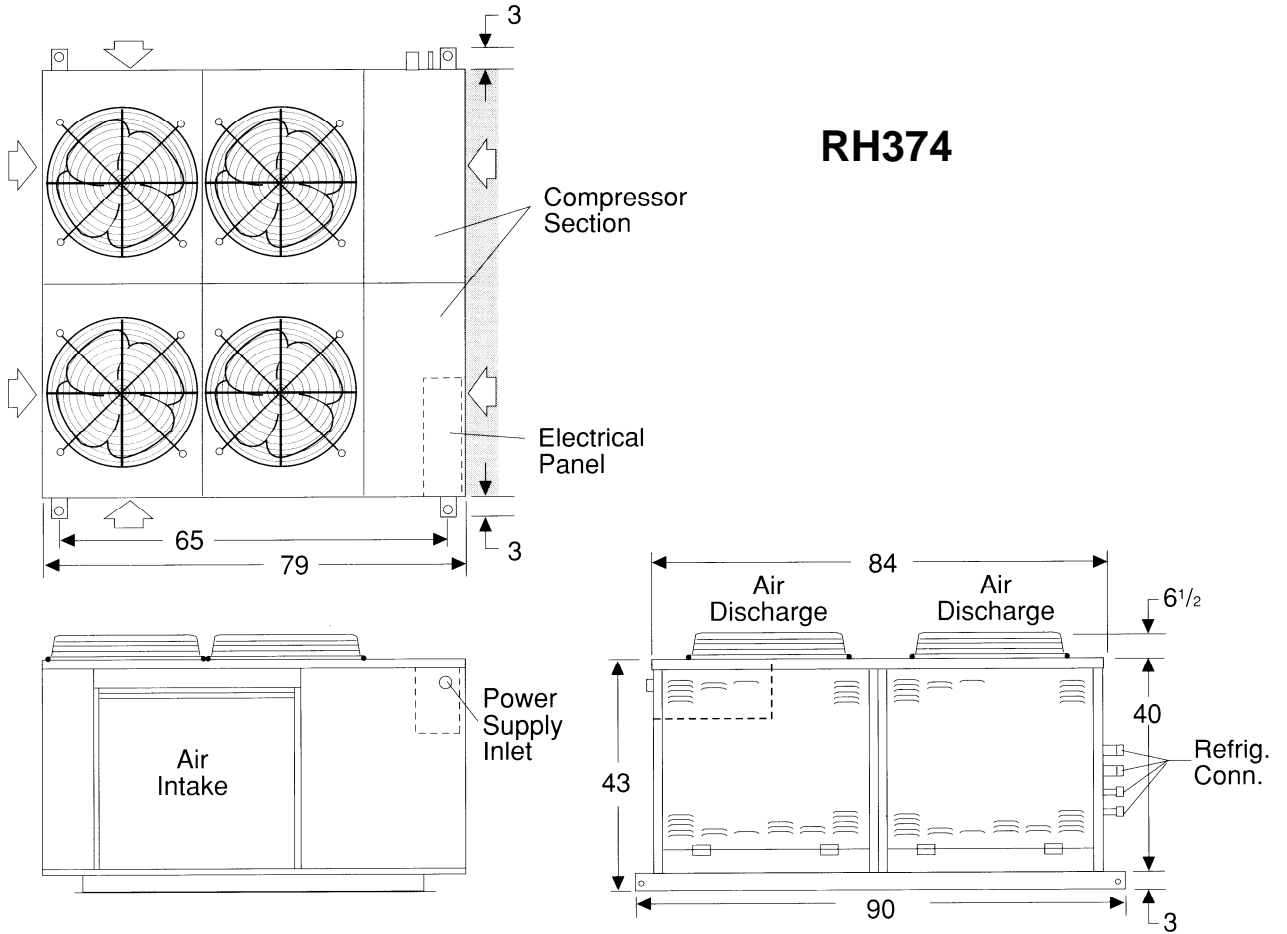

 Indicates air inlet to condenser (leave minimum 2' free clearance).

 Shaded area indicates 3' clearance must be left for access to compressor and electrical panel.

Specifications subject to change without notice.



**Installation Code and Annual Inspections:**

All installations and service of ADDISON equipment must be performed by a contractor qualified in the installation and service of equipment sold and supplied by Addison and conform to all requirements set forth in the ADDISON manuals and all applicable governmental authorities pertaining to the installation, service and operation of the equipment. To help facilitate optimum performance and safety, Addison recommends that a qualified contractor annually inspect your ADDISON equipment and perform service where necessary, using only replacement parts sold and supplied by ADDISON.

**Further Information:** Applications, engineering and detailed guidance on systems design, installation and equipment performance is available through ADDISON representatives. Please contact us for any further information you may require, including the Installation, Operation and Service Manual.

**These products are not for residential use.**

**This document is intended to assist licensed professionals in the exercise of their professional judgment.**



**7050 Overland Road  
Orlando, FL 32810 USA  
Telephone: 407.292.4400  
Fax: 407.290.1329  
[www.addison-hvac.com](http://www.addison-hvac.com)**