



VCH/HCH AIR HANDLER

SPECIFICATIONS – Performance per ARI Std. 210/240						Model 104					
PERFORMANCE	Applied with	EER	COP	CFM	Cooling Sensible BTUH	Cooling Total BTUH		Heating Total BTUH			
	RC074E	9.5	—	3,000	65,500	89,000		—			
	RC084E	9.3	—	3,400	71,100	93,700		—			
	RC104E	9.6	—	3,400	74,500	103,000		—			
	—	—	—	—	—	—		—			
	RH083E	9.0	3.3	3,400	69,800	90,500		93,400			
	RH104E	9.3	3.2	3,400	73,400	99,000		101,700			
—	—	—	—	—	—		—				
ELECTRICAL DATA	SERVICE		Voltage-Phase-Hz			208/230-1-60	208/230-3-60	460-3-60	380/415-3-50		
	1 ½ HP MOTOR		FLA			7.7	4.6	2.3	2.7		
			Unit Minimum Circuit Ampacity			10	6	3	4		
			Max. Time Delay Fuse or HACR Breaker			15	15	15	15		
	2 HP MOTOR		FLA			13.0	6.2	3.1	3.5		
			Unit Minimum Circuit Ampacity			17	8	4	5		
			Max. Time Delay Fuse or HACR Breaker			25	15	15	15		
	3 HP MOTOR		FLA			—	8.0	4.0	4.7		
			Unit Minimum Circuit Ampacity			—	10	5	6		
			Max. Time Delay Fuse or HACR Breaker			—	15	15	15		
	MECHANICAL DATA	EVAPORATOR BLOWER		DWDI, Dia." x Width" (Qty.)			15 x 15 (1)				
		DX Coil		Face Area – Sq. Ft.			8.0				
Rows Deep — Fins per Inch				3 — 14							
Hot Gas Reheat Coil		Face Area – Sq. Ft.			8.0						
		Rows Deep — Fins per Inch			1 / 10						
Liquid Sub Cooling Coil		Face Area – Sq. Ft.			8.0						
		Rows Deep — Fins per Inch			1 / 10						
Chill Water Coil		Face Area – Sq. Ft.			7.6						
		Rows Deep — Fins per Inch			4/12						
Hydronic Heat Coil		Face Area – Sq. Ft.			8.0						
		Rows Deep — Fins per Inch			1/8						
Steam Coil		Face Area – Sq. Ft.			7.3						
		Rows Deep — Fins per Inch			1/8						
Refrigerant Connections		Suction Line (Number) Size			(2) 7/8"						
		Liquid Line (Number) Size			(2) 3/8"						
Condensate Drain		(Number) Size			(2) ¾"						
Filters		(Number) Size			(2) 16 x 15 x 2 — (1) 20 x 25 x 2						
WEIGHTS		Unit (lbs)			405						
		Shipping Weight(lbs)			450						

Blower Performance

	External Static Pressure - Inches H ₂ O													
	0.4		0.6		0.8		1.0		1.2		1.4		1.6	
CFM	RPM	BHP	RPM	BHP	RPM	BHP	RPM	BHP	RPM	BHP	RPM	BHP	RPM	BHP
3000	710	0.9	765	1.0	820	1.2	880	1.4	945	1.5	990	1.7	1045	1.8
3200	725	1.0	775	1.2	830	1.3	890	1.5	955	1.6	995	1.8	1055	2.0
3400	735	1.1	790	1.3	845	1.4	900	1.6	965	1.8	1005	2.0	1065	2.2
3600	750	1.2	800	1.4	855	1.6	915	1.8	975	2.0	1015	2.2	1075	2.4
3800	760	1.3	810	1.5	870	1.7	925	1.9	985	2.2	1025	2.4	1085	2.6

- Notes: 1. For units with electric heat, add 0.20 inches External Static Pressure prior to making R.P.M and B.H.P. selection.
 2. For units with discharge plenum, add 0.02 inches to External Static Pressure prior to making R.P.M and B.H.P selection.
 2. Tables can be interpolated but not extrapolated.

Heating Coil Capacities

CFM	Steam Coil		Hot Water Coil			
	Heating Capacity BTUH*	°F Lvg. Air Temp.	Heating Capacity BTUH**	°F Lvg. Air Temp.	GPM	W.P.D. Ft. Head
3000	167,740	121.3	110,900	103.8	11.4	1.8
3200	173,870	119.9	114,900	102.8	11.8	1.9
3400	179,750	118.6	118,700	101.9	12.2	2.0
3600	185,400	117.3	122,300	101.0	12.6	2.1
3800	190,840	116.1	125,900	100.2	12.9	2.3

Note: Leaving air temperatures are based on 70°F entering air.

Applied Research Laboratories, Inc.



Listed

Steam Coil Correction Factors

Steam Pressure		2 PSIG	5 PSIG
Entering Air Temp. °F	40°	1.12	1.25
	50°	1.13	1.18
	60°	1.06	1.11
	70°	1.00	1.05

Hot Water Coil Correction Factors

Entering Water	Entering Air Temp.			
Temp. °F	40°	50°	60°	70°
160°	0.96	0.90	0.82	0.74
180°	1.08	1.02	0.95	0.87
200°	1.23	1.16	1.08	1.00

4 Row Chilled Water Coil Performance with 45° entering water

CFM	Capacity	Entering Air to Coil								
		75° F DB			80° F DB			85° F DB		
		63°F WB	67°F WB	71°F WB	63°F WB	67°F WB	71°F WB	63°F WB	67°F WB	71°F WB
3000	Total	81,600	103,400	135,300	92,800	109,000	137,600	100,500	116,900	140,500
	Sensible	67,500	61,400	57,400	87,100	79,300	74,100	100,500	98,000	91,100
	LAT	54.6/53.6	56.4/56.0	57.8/57.6	53.7/52.1	56.0/55.3	57.6/57.2	54.1/51.1	55.4/54.2	57.5/56.8
	GPM	16.2	20.6	26.9	18.5	21.7	27.4	19.9	23.3	27.9
	Δ P	7.4	11.6	19.2	9.4	12.8	19.9	10.9	14.6	20.7
3400	Total	89,900	112,100	146,300	100,900	118,600	149,000	110,800	127,400	152,600
	Sensible	74,900	67,300	62,300	96,000	87,400	81,100	110,800	108,300	100,200
	LAT	55.0/53.9	57.0/56.5	58.4/58.3	54.4/52.6	56.7/55.8	58.4/57.9	55.0/51.4	56.1/54.8	58.3/57.5
	GPM	17.9	22.3	29.1	20.0	23.5	29.7	22.0	25.4	30.3
	Δ P	8.9	13.5	22.3	11.0	15.0	23.2	13.1	17.2	24.2
3800	Total	97,500	120,200	156,400	108,500	127,600	159,700	120,600	137,700	163,800
	Sensible	82,000	72,900	66,800	104,400	95,200	87,700	120,600	118,300	108,900
	LAT	55.4/54.2	57.6/57.0	59.0/58.9	55.1/53.0	57.3/56.2	59.1/58.5	55.7/51.8	56.8/55.2	59.0/58.1
	GPM	19.4	23.9	31.1	21.5	25.4	31.8	24.0	27.4	32.6
	Δ P	10.4	15.4	25.3	12.6	17.2	26.5	15.6	20.0	27.7

6 Row Chilled Water Coil Performance with 45° entering water

CFM	Capacity	Entering Air to Coil								
		75° F DB			80° F DB			85° F DB		
		63°F WB	67°F WB	71°F WB	63°F WB	67°F WB	71°F WB	63°F WB	67°F WB	71°F WB
3000	Total	89,000	110,800	152,700	106,100	122,100	156,700	109,300	134,500	162,500
	Sensible	72,400	65,100	64,300	96,300	86,100	82,300	109,300	107,800	101,200
	LAT	53.1/52.7	55.3/55.1	55.6/55.5	50.9/50.4	54.0/53.6	55.1/55.0	51.4/49.9	52.4/52.0	54.4/54.2
	GPM	17.7	22.0	30.4	21.1	24.3	31.2	21.7	26.7	32.3
	Δ P	4.0	6.1	11.3	5.6	7.3	11.9	5.9	8.8	12.8
3400	Total	99,200	122,900	168,600	117,100	135,600	173,100	122,200	149,600	179,800
	Sensible	81,100	72,600	71,000	107,400	96,200	91,400	122,200	120,700	112,700
	LAT	53.4/52.9	55.6/55.4	56.2/56.0	51.3/50.8	54.3/53.9	55.6/55.4	51.9/50.1	52.8/52.3	54.9/54.6
	GPM	19.7	24.4	33.5	23.3	27.0	34.4	24.3	29.8	35.7
	Δ P	4.9	7.4	13.8	6.8	9.0	14.5	7.3	10.9	15.6
3800	Total	109,100	134,700	183,600	128,000	148,600	188,800	134,700	164,100	195,600
	Sensible	89,600	79,900	77,500	118,400	106,100	100,200	134,700	133,200	123,600
	LAT	53.6/53.0	55.9/55.6	56.5/56.4	51.7/51.1	54.7/54.2	56.1/55.9	52.3/50.3	53.2/52.6	55.5/55.1
	GPM	21.7	26.7	36.5	25.4	29.6	37.6	26.8	32.7	38.9
	Δ P	5.9	8.8	16.3	8.0	10.8	17.2	8.9	13.1	18.4

Optional Factory Installed Electric Heat

CFM	KW-->	15	20	25	30	35	40	45	50	55	60
	MBH	51.2	68.3	85.3	102.4	119.5	136.5	153.6	170.7	187.7	204.8
3000	Rise	18.1	24.2	30.2	36.3	42.3	48.4	54.4	60.5	66.5	72.6
3200		16.9	22.5	28.1	33.7	39.3	44.9	50.6	56.2	61.8	67.4
3400		15.7	21.0	26.2	31.5	36.7	41.9	47.2	52.4	57.7	62.9
3600		14.7	19.7	24.6	29.5	34.4	39.3	44.2	49.2	54.1	59.0
3800		13.9	18.5	23.1	27.8	32.4	37.0	41.6	46.3	50.9	55.5
208v 1phase		Amps	72.1	96.2	120.2	144.2	168.3	NA	NA	NA	NA
208v 3 phase	41.6		55.5	69.4	83.3	97.2	111.0	124.9	138.8	152.7	166.5
240v 1 phase	62.5		83.3	104.2	125.0	145.8	166.7	187.5	NA	NA	NA
240v 3 phase	36.1		48.1	60.1	72.2	84.2	96.2	108.3	120.3	132.3	144.3
480v 3 phase	18.0		24.1	30.1	36.1	42.1	48.1	54.1	60.1	66.2	72.2

Recommended Refrigerant Line Sizes – O.D.

Equivalent Line Length — Feet

0 to 25					26 to 50					51 to 75				
Suction	Liquid	Hot Gas Bypass	Hot Gas Reheat		Suction	Liquid	Hot Gas Bypass	Hot Gas Reheat		Suction	Liquid	Hot Gas Bypass	Hot Gas Reheat	
			S	R				S	R				S	R
Two 7/8	Two 3/8	1/2	3/8	3/8	Two 7/8	Two 3/8	1/2	3/8	3/8	Two 7/8	Two 3/8	1/2	1/2	3/8

- Notes:
1. Line lengths are equivalent, including all fittings. Use long radius ells only.
 2. Line sizes are for both vertical and horizontal runs.
 3. Liquid line sizes and hot gas reheat return line sizes are designed to minimize system refrigerant charge.
 4. Over 75 equivalent feet, consult factory for sizing recommendations.
 5. Over 75 total feet, a special hot gas bypass system must be installed in the condensing unit **with an oil separator. Contact factory.**
 6. "S" = Hot gas supply line from RC to VC/HC; "R" = Hot gas return line from VC/HC to RC unit. *Hot gas bypass and hot gas reheat only on lead circuit of dual circuit units. Hot gas bypass and hog gas reheat normally not available for heat pump use.

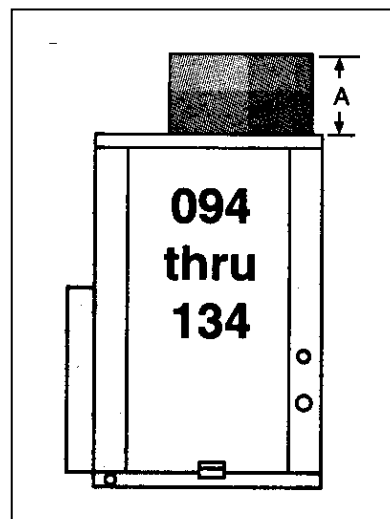
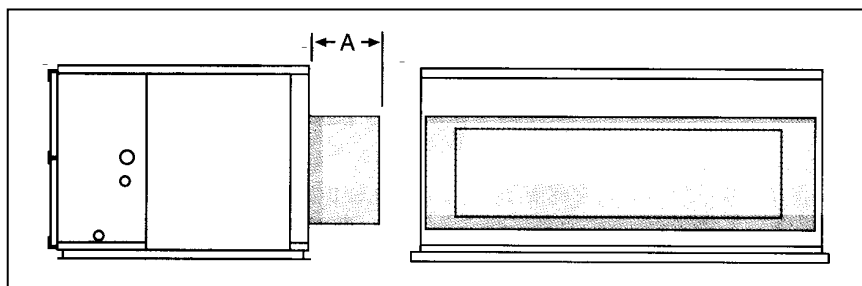

HCH and VCH Discharge electric Heaters
Standard Depth in Direction of Airflow

KW Range	Dim. A (In.)
1 – 60	12

Note: Above values for Dim. A are for standard heaters, with or without air pressure switch, staging relay and non-fused disconnect. Addition of more options may require longer Dim. A. If space considerations are critical, contact factory for exact information.

Note: electric heat sections are designed for mounting directly to air handler cabinet. Electrical box is on the same end as air handler fan motor. Sub-circuit fusing is included when required. Disconnect to be furnished and filed installed by contractor.

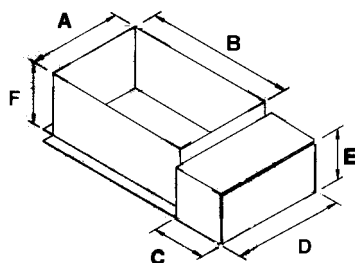

	Electric Heaters						
	kW Range	A	B	C*	D*	E	F
VCH	1 – 30	16 1/4	18 7/8	12	18 1/4	11	12
	31 – 60	16 1/4	18 7/8	15	18 1/4	11	12
HCH	1 – 30	18 1/4	20 7/8	12	20 1/4	11	12
	31 – 60	18 1/4	20 7/8	15	20 1/4	11	12

* These dimensions may vary with added heater options. Contact factory if space considerations are critical.

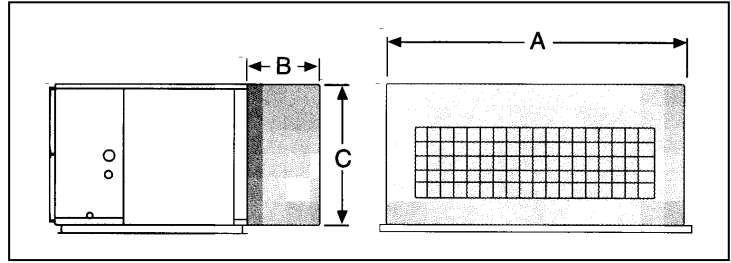
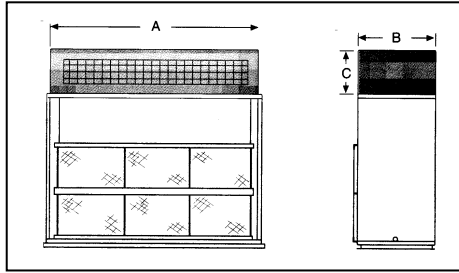

Discharge Plenum with 4 way Adjustable Grill

	A	B	C
HCH Model	54	24	28 1/4
VCH Model	56	29	24

Plenums are fully insulated and shipped separate for field assembly to the air handler and can be installed 180 degrees from the view shown on the drawing.

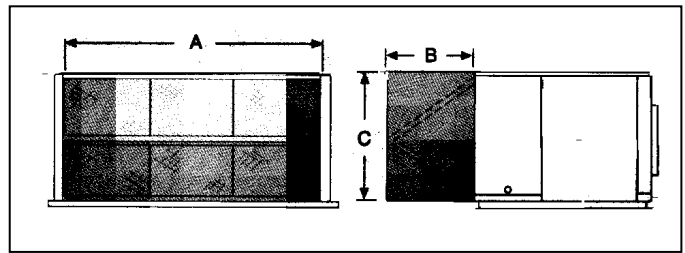
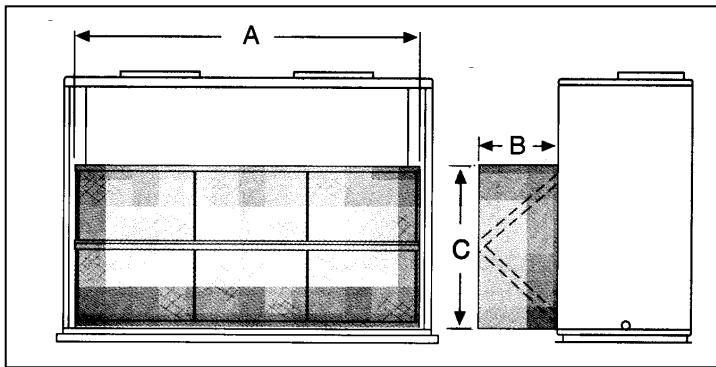

Angle Filter Section

	A	B	C	Filters, Qty. - Size
HCH	50	24	25 1/4	6 - 16 x 20
VCH	50	29	25 1/4	6 - 16 x 20

Filter sections are fully insulated and shipped separate for field assembly to the air handler. 2 - inch glass fiber media filters standard.

VCH Model

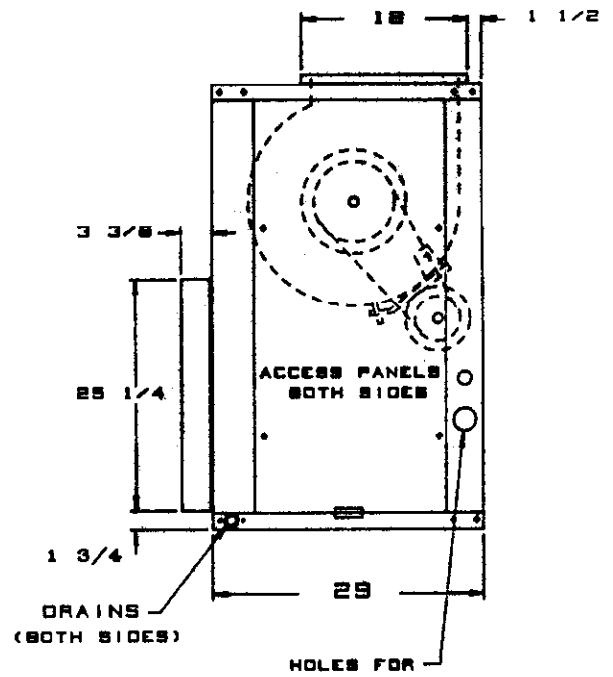
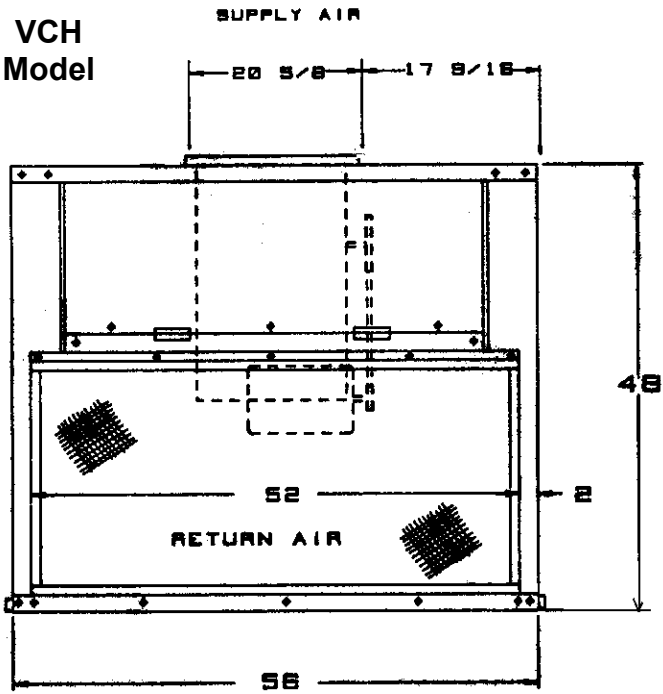

HCH Model

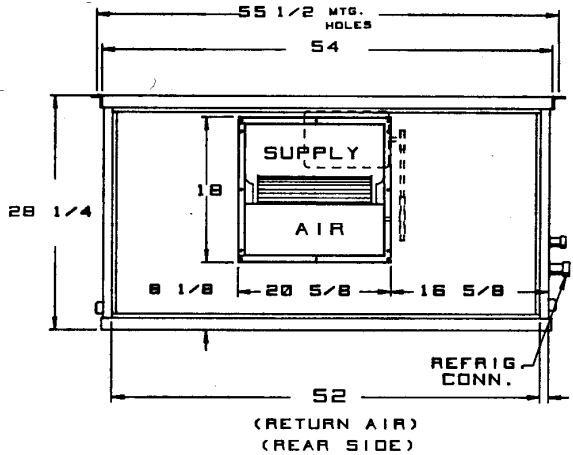
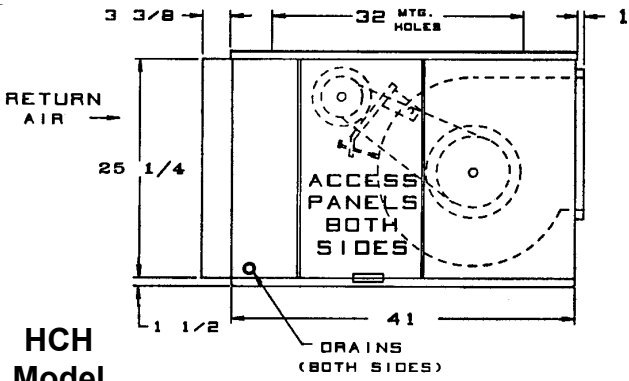

Installation Code and Annual Inspections:

All installations and service of ADDISON equipment must be performed by a contractor qualified in the installation and service of equipment sold and supplied by Addison and conform to all requirements set forth in the ADDISON manuals and all applicable governmental authorities pertaining to the installation, service and operation of the equipment. To help facilitate optimum performance and safety, Addison recommends that a qualified contractor annually inspect your ADDISON equipment and perform service where necessary, using only replacement parts sold and supplied by ADDISON.

Further Information: Applications, engineering and detailed guidance on systems design, installation and equipment performance is available through ADDISON representatives. Please contact us for any further information you may require, including the Installation, Operation and Service Manual.

These products are not for residential use.

This document is intended to assist licensed professionals in the exercise of their professional judgment.



**7050 Overland Road
Orlando, FL 32810 USA
Telephone: 407.292.4400
Fax: 407.290.1329
www.addison-hvac.com**