

MODEL	A	B	C	D	F.L.A.	W (LBS)
HDA 150-F	14.93	39.84	20.93	31.39	4A	244.00
HDA 200-F	14.93	39.84	20.93	31.39	4A	232.00
HDA 250-06-F	21.43	39.84	27.43	31.39	4A	278.00
HDA 300-F	21.43	39.84	27.43	31.39	4A	278.00
HDA 350-08-F	27.93	39.84	33.93	31.39	4A	439.00
HDA 400-F	27.93	39.84	33.93	31.39	4A	439.00
HDA 500-F	34.43	39.84	40.43	31.39	5A	480.00
HDA 600-F	40.93	39.84	46.93	31.39	5A	522.00
HDA 350-F-X2	24.68	30.68	33.77	62.78	8A	668.00
HDA 400-F-X2	27.93	39.84	33.93	62.78	8A	923.00
HDA 500-F-X2	34.43	39.84	40.43	62.78	10A	1011.00
HDA 600-F-X2	40.93	39.84	46.93	62.78	10A	1086.00

REV	DESCRIPTION	DATE	BY	CKD BY	PCN
-	-	-	-	-	-

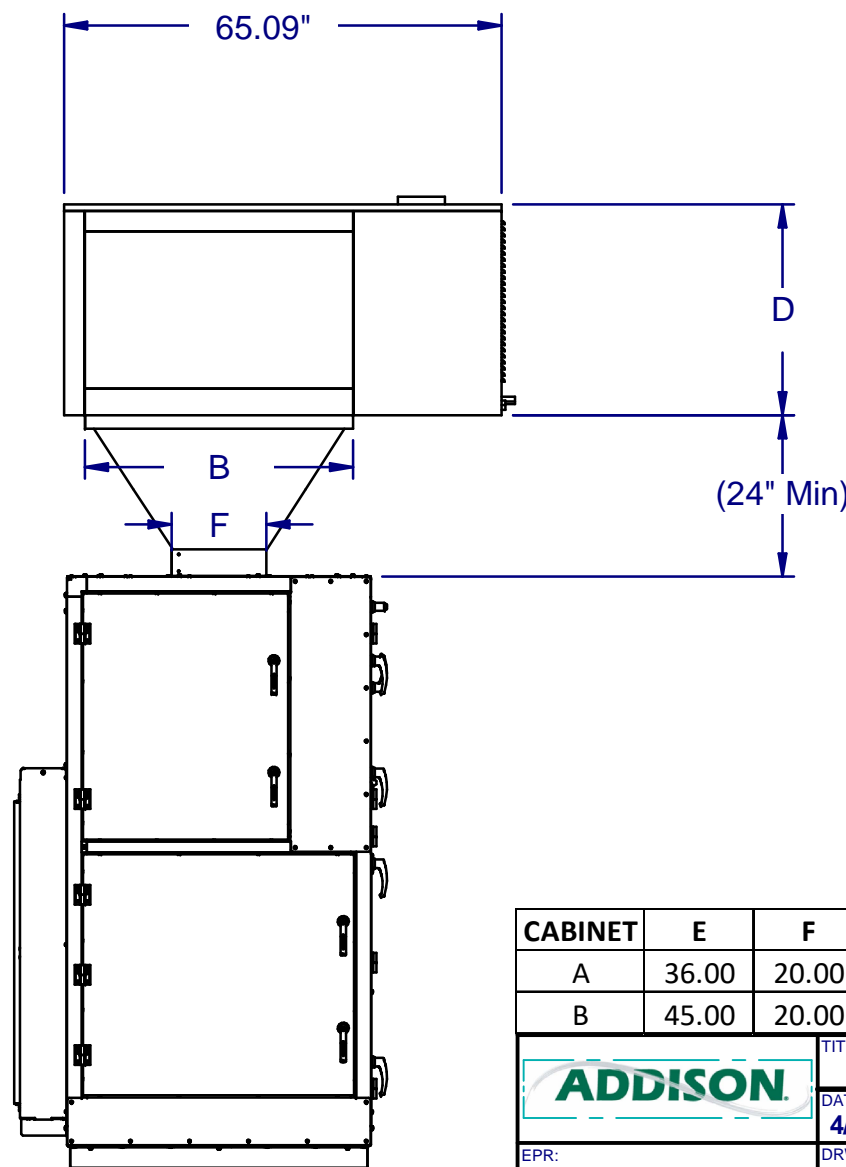
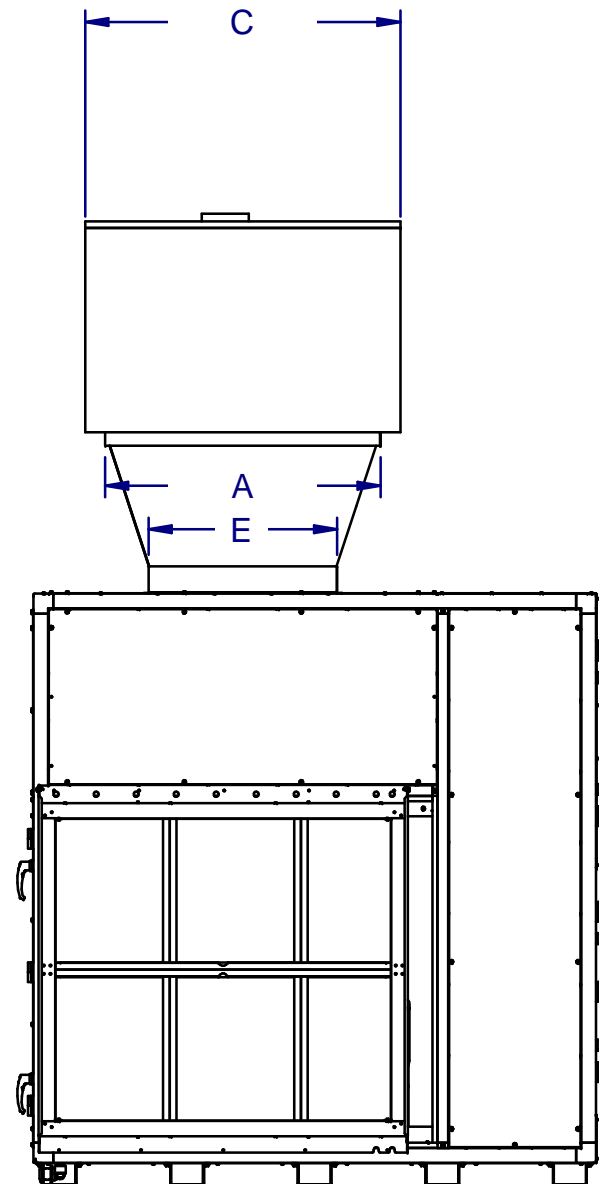
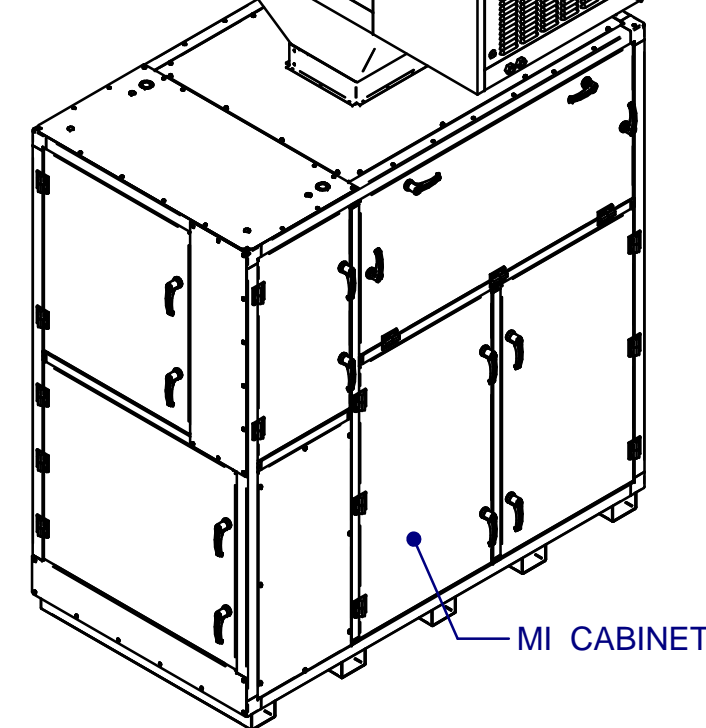
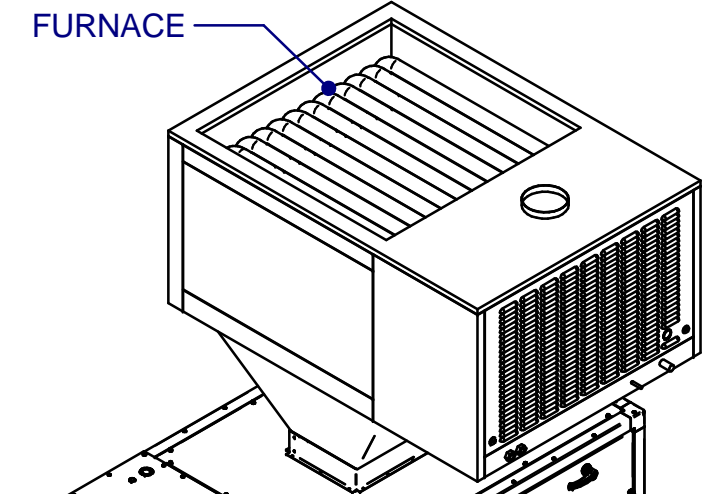
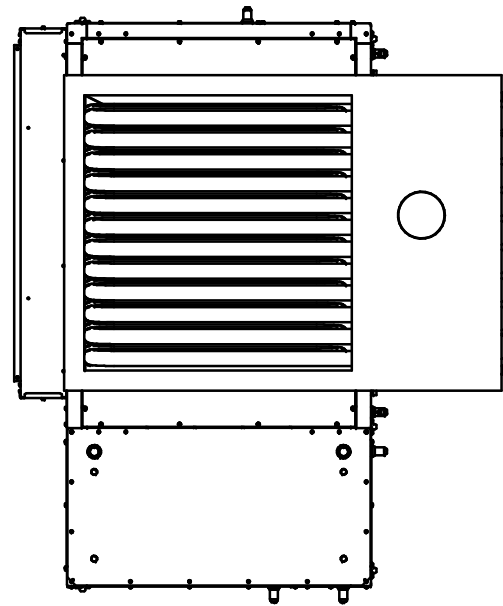

CABINET	E	F
A	36.00	20.00
B	45.00	20.00

Note:
Duct gas furnace module ships separately and requires a 120V power supply (not powered by the AHU). Furnace can be controlled by the AHU through the ALC controller, if provided.

ADDISON		TITLE ADDISON MI FURNACE VERTICAL			
DATE 4/14/2021	CKD DW	APPD GO	PART #	SHEET #	REV
EPR: EPR #			07951-5008	1	A
DRWN: Carlos.Barbas					