

100% OUTSIDE AIR WITH RECIRCULATING OPTION OR MIXED AIR

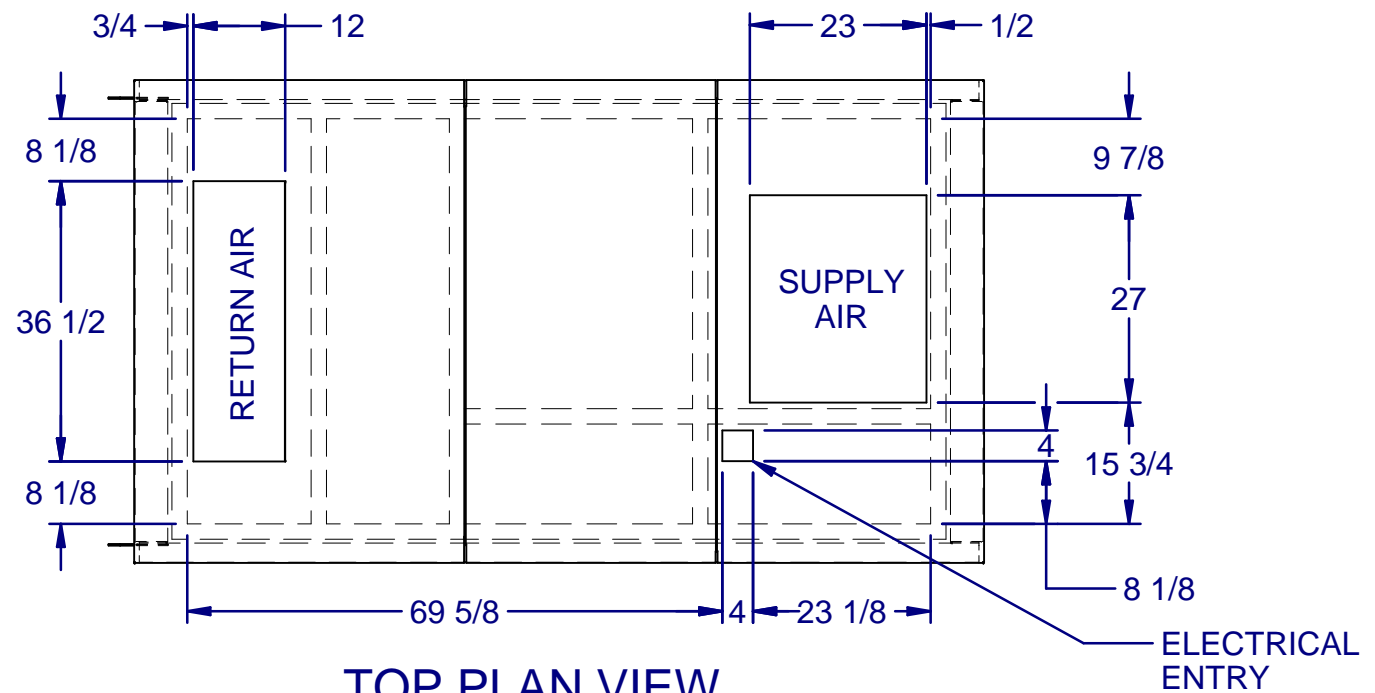
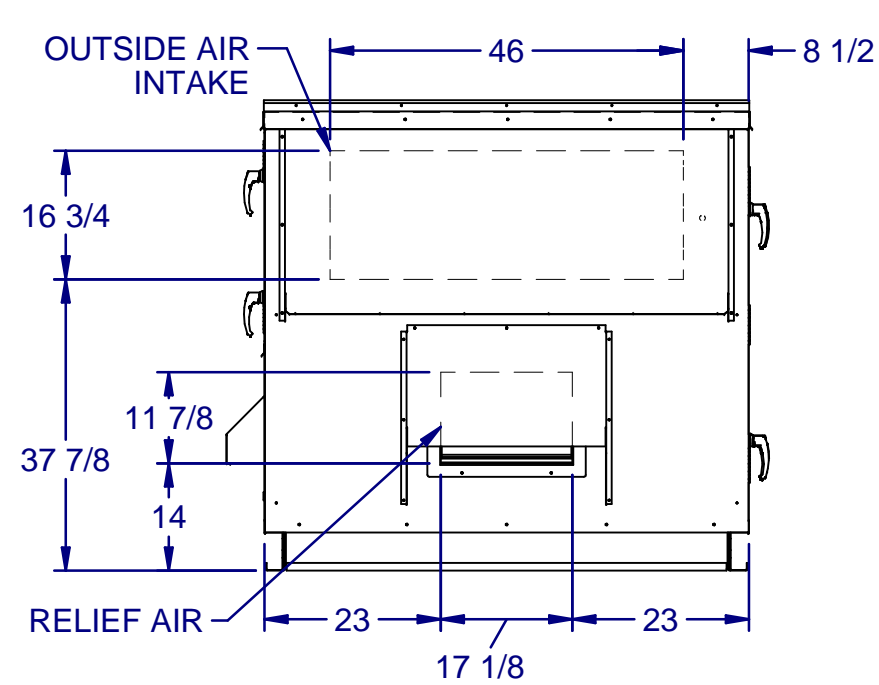
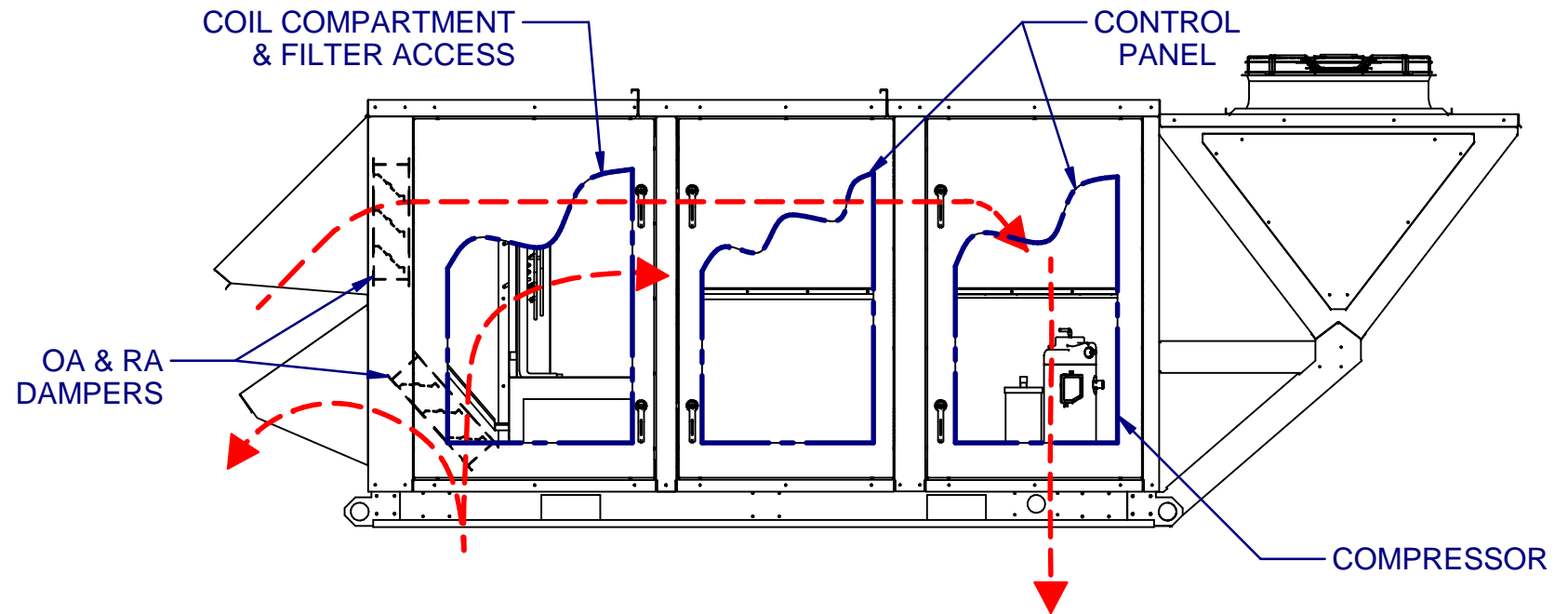

TOP PLAN VIEW
CONDENSING SIDE
NOT SHOWN

DRAWING NUMBER: 0504I-2514-3	12/21/2015
TITLE: PR B2XL CAB NO EXH	1 OF 1