

DRAWING NUMBER: 05041-2529	12/21/2015
TITLE: PR WG C CAB	1 OF 2

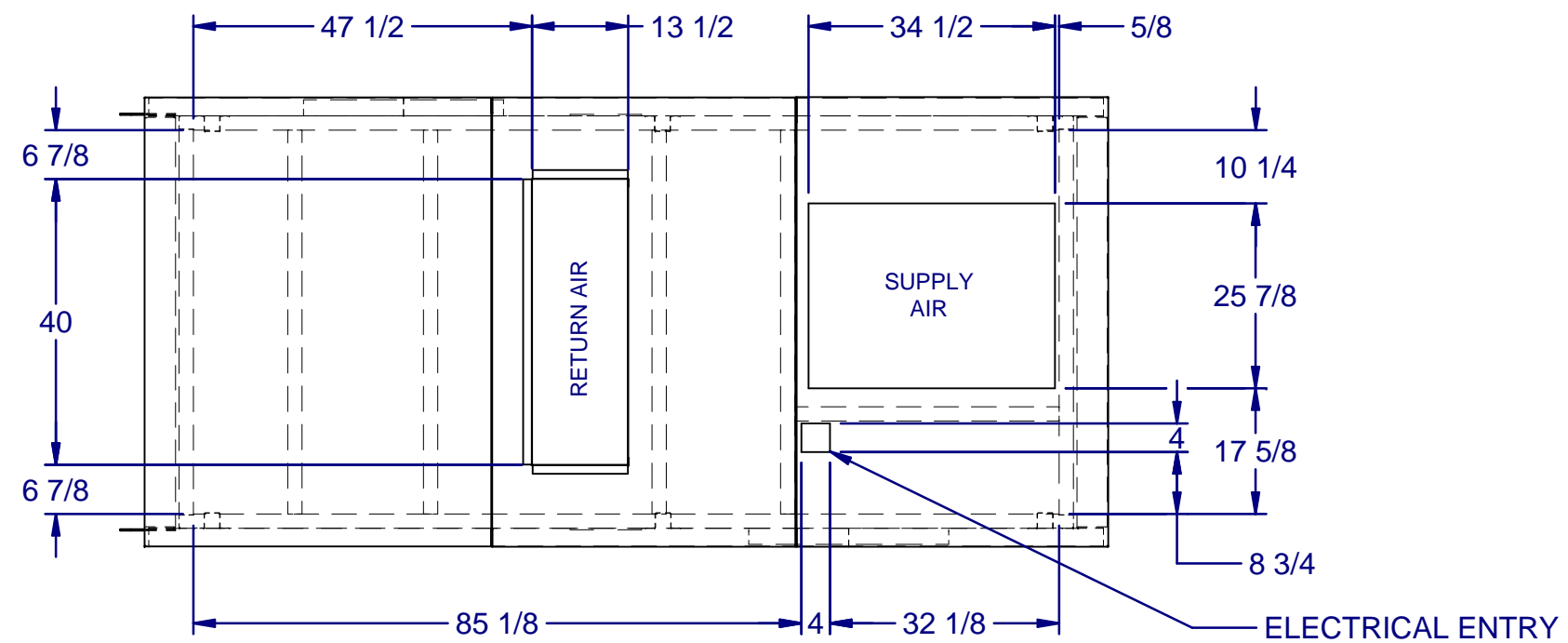
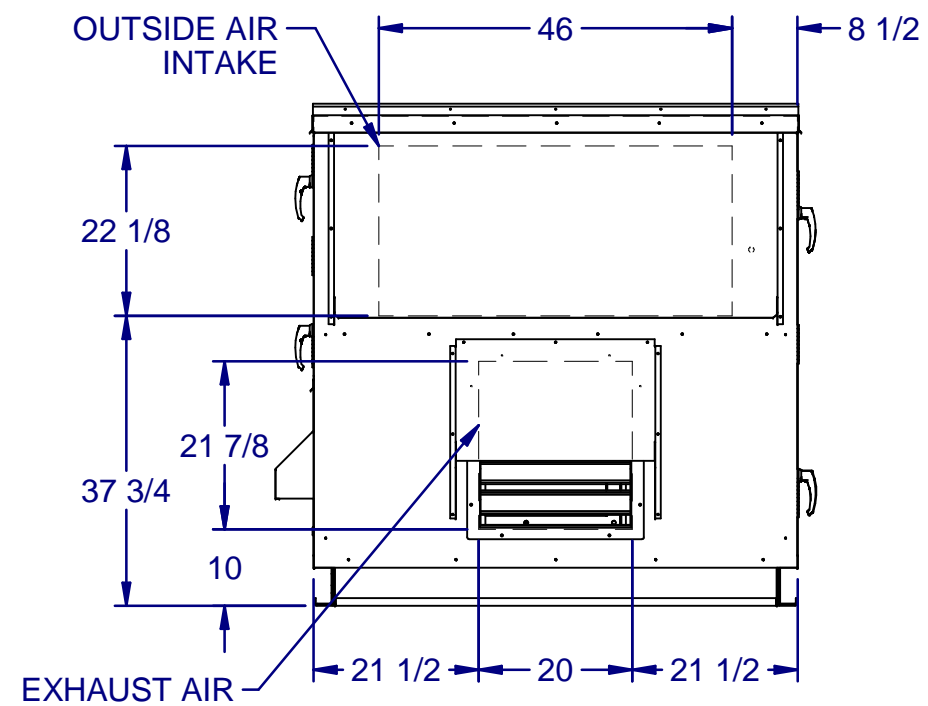
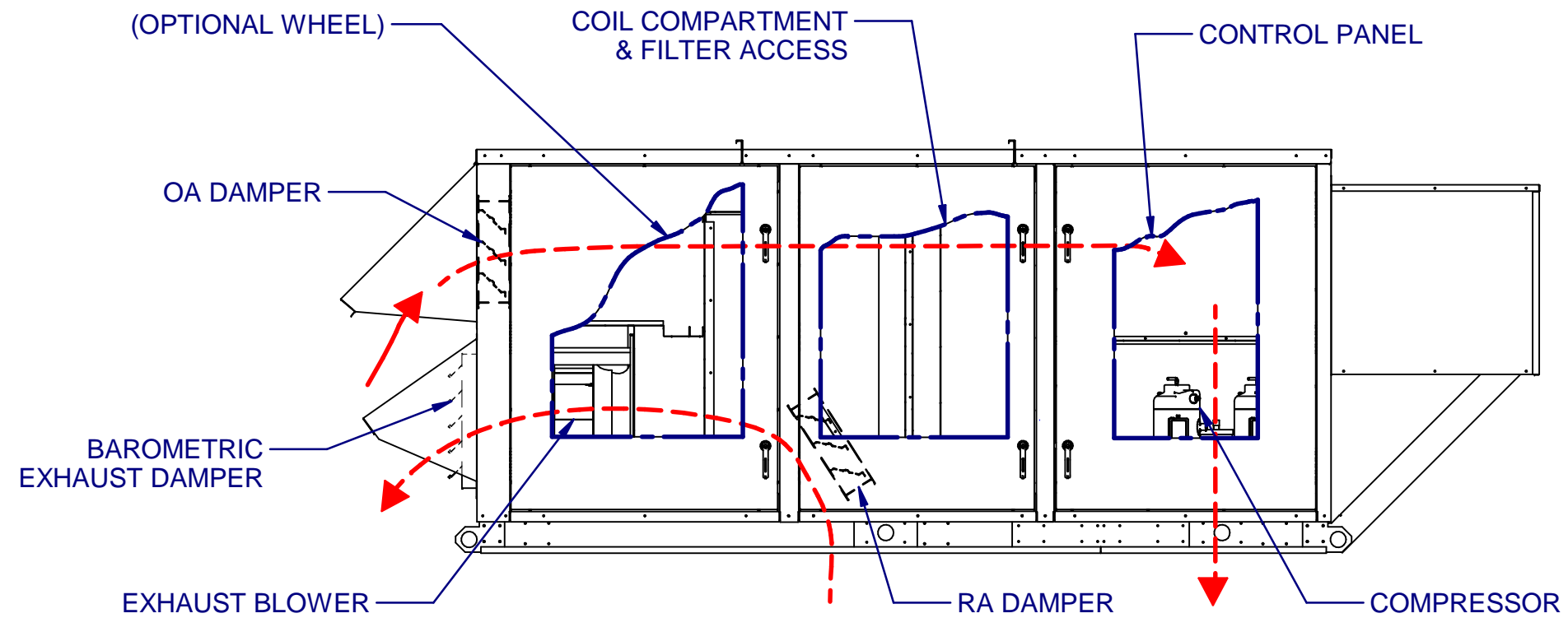

TOP PLAN VIEW
 CONDENSING SIDE
 NOT SHOWN

DRAWING NUMBER: 05041-2529	12/21/2015
TITLE: PR WG C CAB	2 OF 2